

SUPERFRAC[®]

High Performance Trays

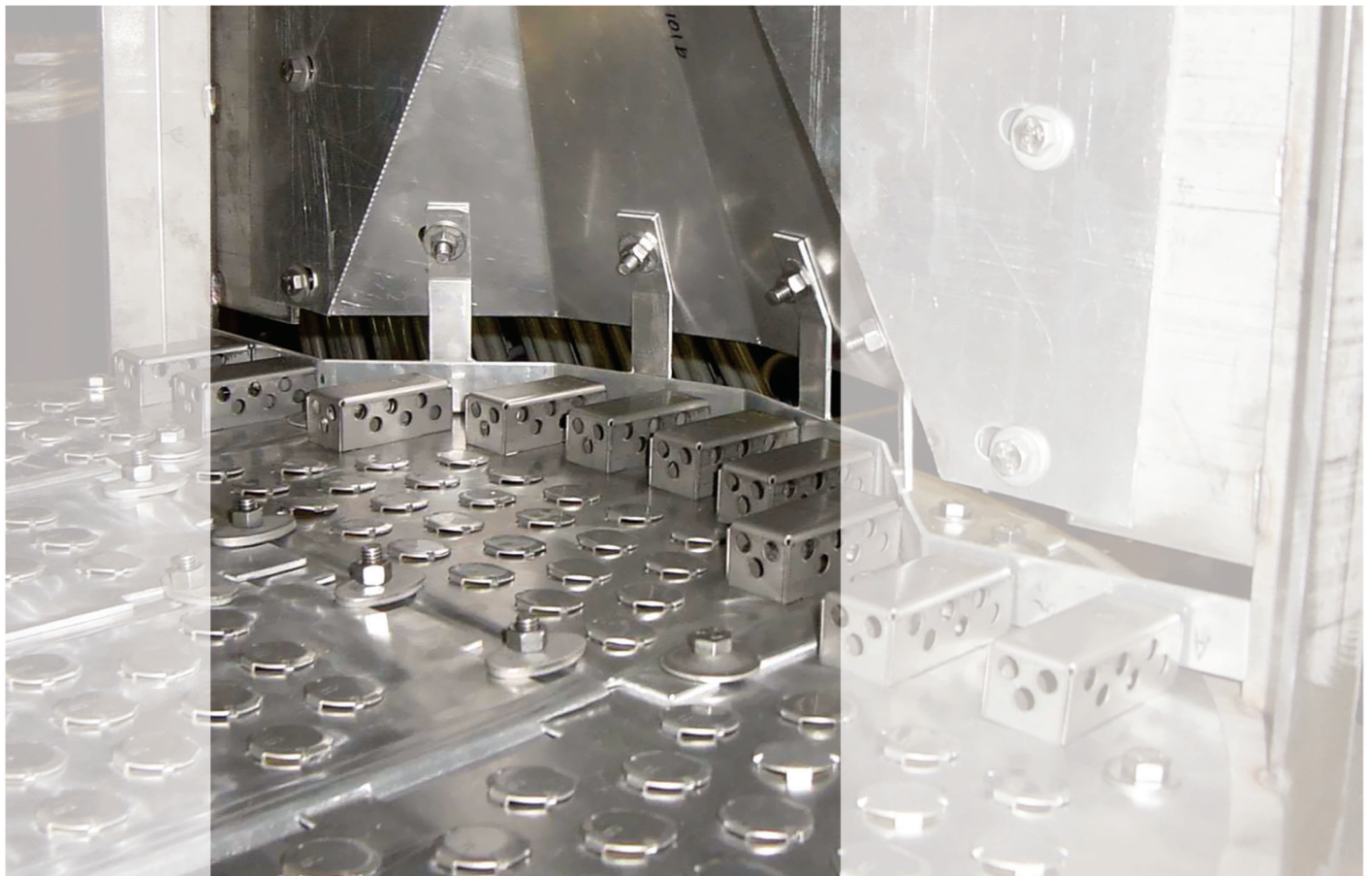

YOU CAN RELY ON US.

 KOCH-GLITSCH[®]

SUPERFRAC® High Performance Trays

The SUPERFRAC® tray is a high performance cross-flow tray that has the highest combined capacity and efficiency of all single-pass cross-flow trays tested at Fractionation Research Inc. (FRI).

The patented technologies used in SUPERFRAC® trays are the culmination of over twenty-five years of comprehensive tray development work. The unique combination of SUPERFRAC patented technologies and design strategies produces the high capacity and the maximum vapor/liquid contact efficiency achievable on a cross-flow distillation tray. As a result, the SUPERFRAC tray gives the highest economic benefit to operators of distillation columns seeking solutions for both new construction and revamp projects.

A well-designed conventional tray generally provides the most economically attractive solution for grass-roots column construction projects. However, as the operator's throughput and product requirements increase, the original trays become the primary constraint. Conventional tray design limitations include:

- Liquid and/or vapor maldistribution that can reduce tray efficiency and lead to premature flooding because of entrainment.
- Less-than-optimal downcomer design that can ultimately result in premature downcomer flooding.

Such performance issues of conventional trays have been recognized for many years. Koch-Glitsch has invested significant research and development resources to



Two-pass SUPERFRAC® tray

understand these issues and to strategically address each one of them. SUPERFRAC trays and the know-how to design and apply them are the products of that investment.

Koch-Glitsch has targeted three major areas for enhancing the performance of conventional trays:

- Advanced downcomer technology
- Active area enhancements
- Inlet area enhancements

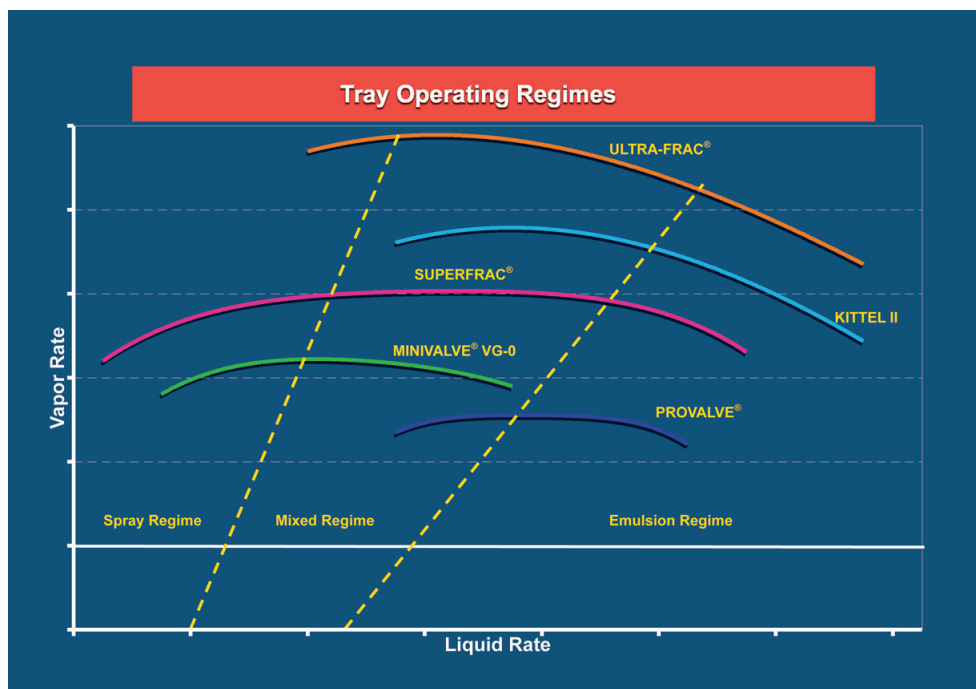

Enhancements

Advanced Downcomer Technology

A thorough understanding of downcomer flooding mechanisms in a wide variety of services is critical to successful application of high performance tray technology. Advanced downcomer technology developed by Koch-Glitsch provides the capability to accurately size and shape the downcomer, which provides the following benefits:

- Conventional downcomers for standard tray construction and simple installation
- Truncated downcomers to maximize active area for vapor-liquid contact
- Multi-chordal side downcomer skirts for longer flowpath length and greater efficiency
- Multi-pass downcomers for reduced weir loading and improved column capacity
- PURGE downcomers as the ultimate solution for solids handling in severe fouling services

Active Area Enhancements

Koch-Glitsch has developed a variety of valve styles and technologies to enhance the vapor-liquid contacting that takes place on a tray deck:

- MINIVALVE® decks
 - VG-0 fixed valves
 - MV-1 floating valves
- Large diameter fixed valves
- Bubble promoters
- Proprietary design techniques

The variety of valve styles and technologies are used to enhance the effective bubbling activity on the tray and improve the flow of fluid across the tray. This results in improvement to both hydraulic performance and mass transfer efficiency on the deck.



VG-0 Fixed Valves



MV-1 Floating Valves

Inlet Area Enhancements

Inlet area enhancements, such as bubble promoters, can provide improved capacity, better froth initiation, and improved bubbling activity on the tray, thus also increasing vapor-liquid contact efficiency.

SUPERFRAC trays use inlet area enhancements to eliminate the vapor and liquid maldistribution and stagnant zones that can occur on conventional trays. These enhancements promote uniform flow distribution, which improves the hydraulic performance and contact efficiency of the tray.



Bubble Promoter

Fouling Services

Moderate Fouling Services

For moderate fouling systems, large diameter fixed valves, such as the VG-10 or the patented PROVALVE® unit, can be used to reduce the tendency to foul.

The VG-10 and PROVALVE valves are directional valves. The liquid push provides a cleansing action to the tray deck that is strong enough to help flush solid material downstream and toward the downcomer where it can exit the tray deck.

The large openings of the VG-10 and PROVALVE valves provide improved fouling resistance because it is much more difficult for fouling material to deposit and choke off the openings. With extended time between shutdowns and ease of cleaning, there is less downtime. As with any fixed valve, they cannot stick shut nor can they spin.

The VG-10 full-size fixed valve can be supplied with a net rise of up to 0.551 in [14 mm] in many materials.

The PROVALVE valve is a fixed device that is inserted into the deck rather than being formed. As such, it can be manufactured in a wider range of materials, including brittle materials such as titanium and zirconium and even plastics.

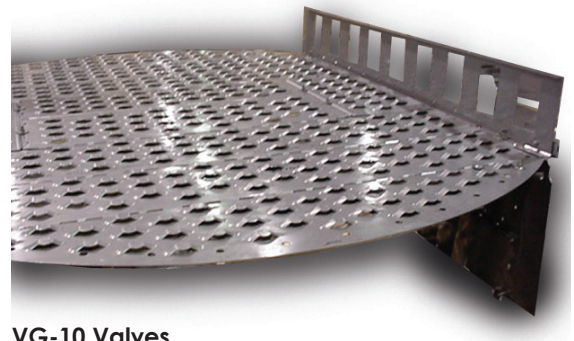

VG-10 Valves

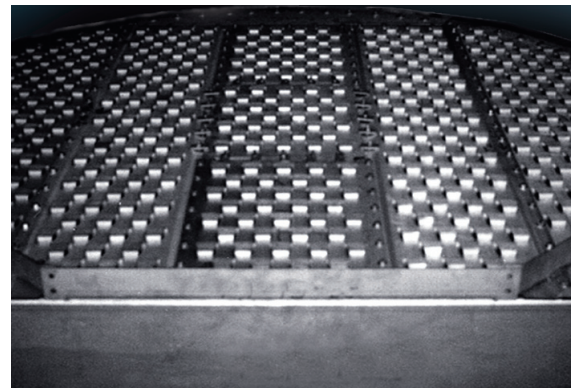

PROVALVE® Valves

Extreme Fouling Services

For extreme fouling services, Koch-Glitsch offers SUPERFLUX® trays, which can employ many of the capacity and efficiency features of SUPERFRAC trays. SUPERFLUX trays are designed to increase run time in fouling applications. Koch-Glitsch can address specific fouling characteristics with proprietary technology offered on SUPERFLUX trays.

The VG-10 large diameter fixed valve is widely used on SUPERFLUX trays. The large net rises available plus the directional liquid push make the VG-10 an outstanding anti-fouling valve.

The PURGE downcomer is available for severe fouling applications, such as polymer slurry, acrylonitrile, and butadiene services.

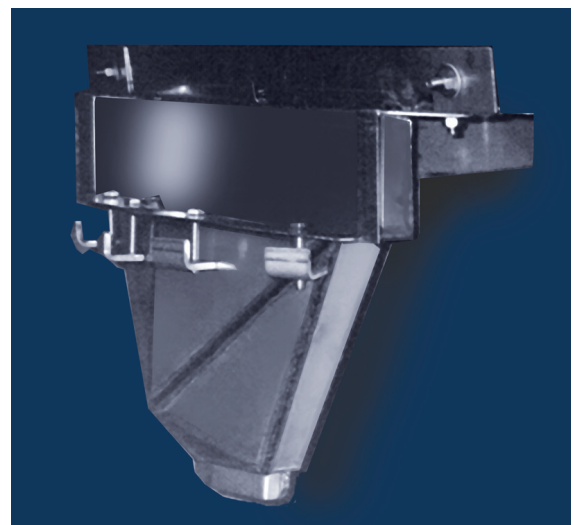

SUPERFLUX® trays with PURGE downcomer option resist fouling in very severe applications.

SUPERFLUX® Trays

To ensure the appropriate technologies are applied for each SUPERFLUX® tray design, specific characteristics of fouling must be addressed. Features suitable for the specific application are then combined into a final design to produce a tray capable of longer run times between cleaning shutdowns.

Conventional Downcomers

SUPERFLUX trays with conventional downcomers use active area enhancements and may have inlet area enhancements. Large diameter fixed valves that are fouling resistant are a standard feature. The straightforward design of the downcomers allows the use of standard tray construction and simplifies installation.

SUPERFLUX trays provide increased fouling resistance, which can lead to increased run times. Several valve options are available that promote self-cleaning of the active areas. These valves have directional components that use vapor energy to provide forward-lateral push on the froth. This action is critically important to maintain proper tray activity and reduce residence time of solids on the tray deck.

Particular attention is paid to the peripheral areas of the deck where stagnation may lead to solids deposition. Directional valves are placed in this area to both increase activity as well as promote a uniform flow profile. These components combine to reduce the residence time distribution and enhance the fouling resistance of the trays. Such a tray design is suitable for processes that are particularly prone to active area fouling, such as sour water strippers and beer strippers. The PURGE downcomer configuration is recommended in processes where downcomer fouling is known to cause frequent shutdowns.

PURGE Downcomers

If conventional downcomers do not provide the optimum design for resisting fouling in your application, Koch-Glitsch offers the PURGE downcomer. For very severe applications, the PURGE downcomer has proven suitable to resist fouling for such services as polymer slurry, acrylonitrile, and butadiene services.

The PURGE downcomer SUPERFLUX trays use active area enhancements and may have inlet area enhancements. Very specific advanced downcomer technologies have been applied to the PURGE downcomer trays.

Overview

- Diameters from 3 ft [900 mm]
- Fouling resistant with large fixed valves
- Conventional downcomer design allows simple revamps
- PURGE downcomer design is the ultimate solution for sediments
- Directional valves promote self-cleaning of active area

Construction Details

- Conventional style downcomers that are either straight or sloped
- PURGE downcomers for very severe services
- Custom-engineered designs for specific applications
- FLEXILOCK® construction

Design Options

- Valve options: VG-0, VG-10, PROVALVE
- Proprietary design techniques
- Bolted design
- Electropolishing

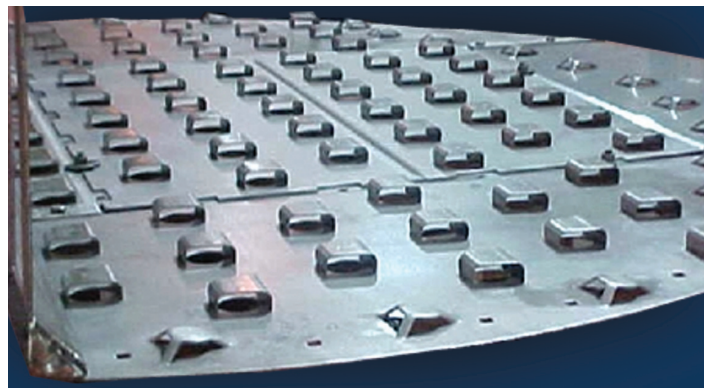

SUPERFLUX® Tray for Bioethanol Beer Stripper

Downcomer Selection

Conventional Downcomer SUPERFRAC® Trays

Conventional downcomer SUPERFRAC trays use active area enhancements and may include inlet area enhancements. Refer to page 3 for additional descriptions of enhancements.

The straightforward design of the downcomers allows use of standard tray construction and simplifies installation, which may allow a lower cost solution.

Some improvements in capacity and efficiency are possible over conventional trays by changing the active areas. In some cases, the higher capacity valves and optimized liquid push can achieve revamp goals without downcomer modifications.

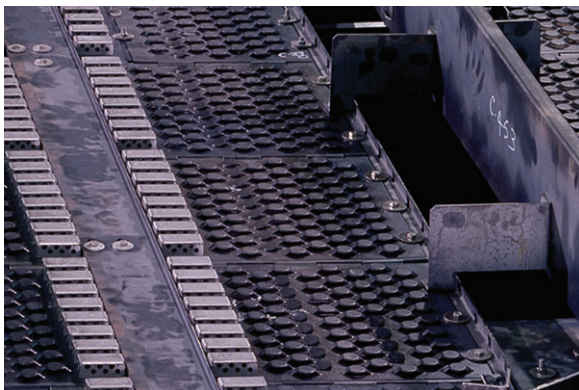

Characteristics

- Diameters from 3 ft [900 mm]
- Fouling resistant with large diameter fixed valves
- Downcomer design provides simple revamps
- No extra active area over conventional designs

Construction Details

- Conventional-style downcomers that are either straight or sloped
- Custom designs for specific application requirements
- FLEXILOCK construction

Design Options

- Valve options: VG-0, VG-10, PROVALVE, MV-1, and CRV
- Optimized liquid push
- Bubble promoters
- Bolted design

Multi-pass Downcomer SUPERFRAC® Trays

In larger diameter columns, typical multi-pass designs are limited to four passes. However, for applications that require more than four passes, the proprietary multi-pass downcomer design can be used to reduce weir loading and improve the capacity of the column.

Koch-Glitsch has successfully designed large diameter columns that use these multi-pass design techniques in 6-pass or 8-pass configurations. Modest capacity increases with these trays are possible in comparison to the best designed 4-pass SUPERFRAC trays.

The downcomer configuration for a multi-pass design typically is the multichordal design; however, virtually any other configuration can be used.

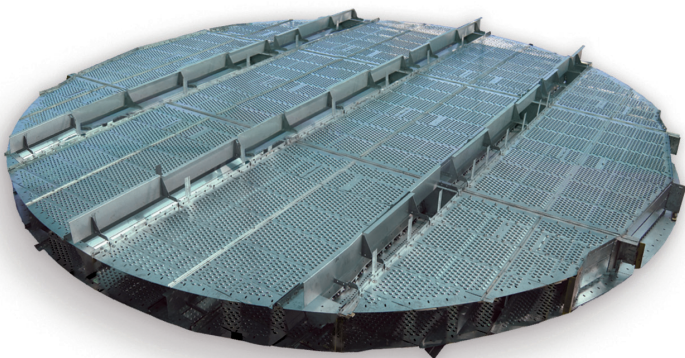

Characteristics

- Diameters from 13 ft [3962 mm]
- High liquid rates
- Multiple downcomer designs

Construction Details

- Truncated or multi-chordal downcomer design
- Custom designs for specific application requirements
- FLEXILOCK construction
- Bubble promoters

Design Options

- Valve options: VG-0, VG-10, PROVALVE, MV-1, and CRV
- Optimized liquid push
- Customized downcomer design
- Proprietary design techniques
- Bolted design

Truncated Downcomer SUPERFRAC® Trays

Truncated downcomer SUPERFRAC trays use active area enhancements and advanced downcomer technologies and may include inlet area enhancements.

Several patented truncated downcomer designs are available and are customized to the specific application. The tray design takes the vapor and liquid rates into consideration as well as special requirements, such as fouling service.

MINIVALVE decks use either the VG-0 or MV-1 valves with corresponding push valves. The PROVALVE and VG-10 valves are available options that achieve high rates and have larger openings that offer improved reliability for fouling applications.

Capacity gains for these trays can be substantial, particularly in cases where the existing conventional trays had large inlet areas below the downcomers. In these cases, the recovered area under the downcomer can create a drastic increase in capacity. At higher capacities, testing has shown that these trays still maintain high efficiencies. Under most conditions, the efficiency of these trays is higher than conventional trays.

Lower cost options are considered during the design process while recognizing the required capacity and efficiency. More complicated designs are not used if simpler ones will suffice.

Characteristics

- Diameters from 3 ft [900 mm]
- Fouling resistant with large diameter fixed valves
- Downcomer maximizes active area in comparison to conventional designs
- Equal or better efficiency in tray-for-tray revamps

Construction Details

- Truncated-style downcomers that are either straight or sloped
- Custom designs for specific application requirements
- FLEXILOCK construction

Design Options

- Valve options: VG-0, VG-10, PROVALVE, MV-1, and CRV
- Bubble promoters for applicable liquid rates
- Proprietary design techniques
- Bolted design

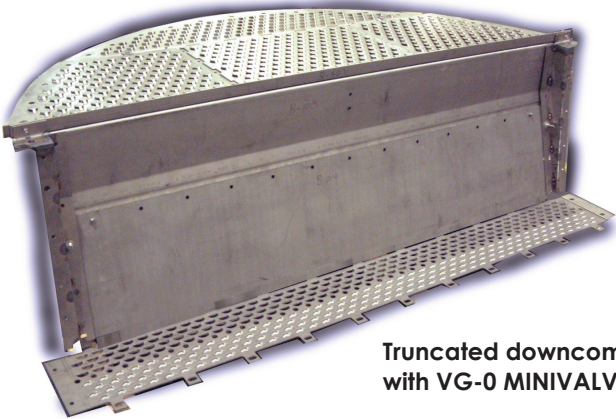

Truncated downcomer SUPERFRAC® tray with VG-0 MINIVALVE® decks.

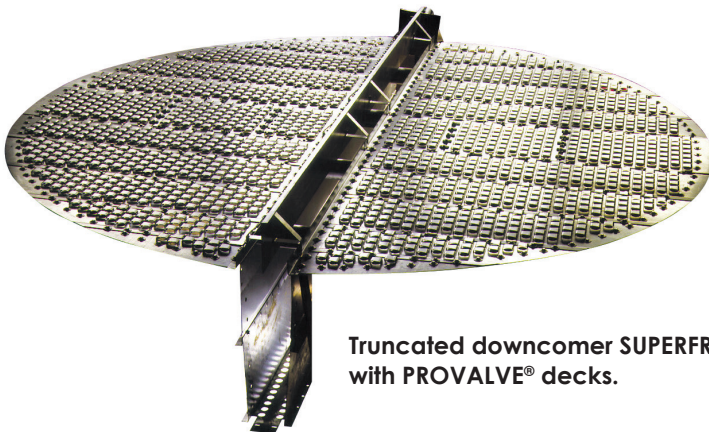

Truncated downcomer SUPERFRAC® tray with PROVALVE® decks.

Multi-chordal Downcomer SUPERFRAC® Trays

The patented multi-chordal downcomer SUPERFRAC tray uses active area enhancements and advanced downcomer technologies and may include inlet area enhancements.

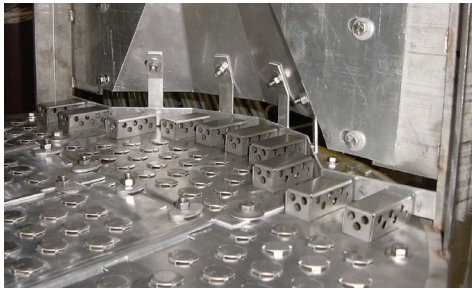

The multi-chordal downcomer design uses the full vertical tray space, which minimizes downcomer limitations.

In this design, the bottom downcomer area is located over the tray support ring, thereby using an area that cannot be used as an active area.

Capacity gains for these trays can be substantial, particularly in cases where the existing conventional trays had large inlet areas below the downcomers. At higher capacities, testing has shown that these trays maintain high efficiencies. Generally, the efficiency of these trays is higher than conventional trays.

The multi-chordal shape of the side downcomer at the bottom provides additional benefits.

- Equalized liquid flow patterns across the tray
- Increased flow path length
- Increased vapor-liquid contact time
- Improved efficiency
- Increased bubbling area and tray capacity

The shape of the multi-chordal downcomer allows a conversion from straight to sloped downcomers without the use of downcomer adapter bars. This saves the extra cost of the adapters and the field time needed to install them. It also eliminates the need to weld to the vessel shell.

MINIVALVE decks use either the VG-0 or MV-1 valves with corresponding push valves.

The forward-lateral push provided by the optimized liquid push design promotes uniform liquid and vapor distribution across the entire tray deck. This suppresses jet flooding and permits operation at higher flow rates. The typical liquid recirculation found on most conventional trays results in lower efficiency and capacity. This liquid recirculation is eliminated with the appropriate liquid push design.

Characteristics

- Diameters from 3 ft [900 mm]
- Design maximizes active area over conventional designs
- Downcomer design uses entire tray space
- Equal or better efficiency in tray-for-tray revamps

Construction Details

- Multi-chordal style side downcomers
- Custom designs for specific application requirements
- FLEXILOCK construction

Design Options

- Valve options: VG-0, VG-10, PROVALVE, MV-1, and CRV
- Optimized liquid push
- Bubble promoters for applicable liquid rates
- Proprietary design techniques
- Bolted design

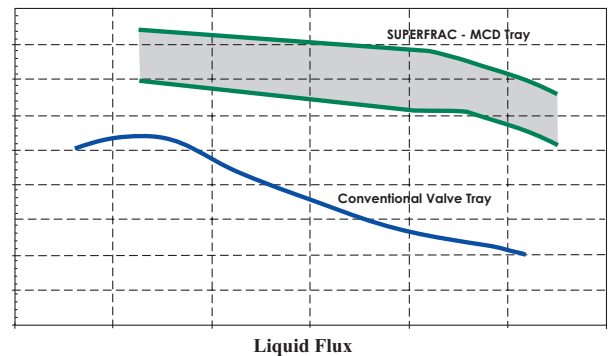

Capacity gains for SUPERFRAC® trays can be substantial while still maintaining high efficiencies.

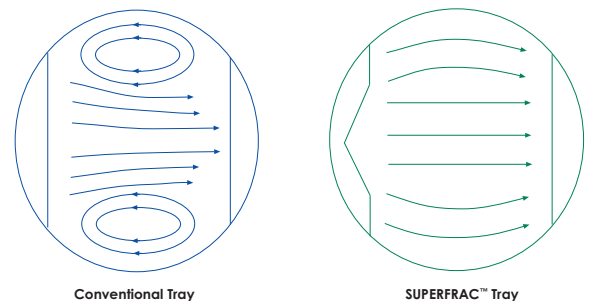

Liquid flow distribution comparison between conventional trays with truncated downcomers and a multi-chordal SUPERFRAC® tray.

PLUS Technology for SUPERFRAC® Trays

The patented PLUS technology acts as a deentrainment device and can decrease the efficiency loss that often occurs in low liquid and high vapor rate applications. In these types of conditions, it is common for high vapor rates to blow the liquid off the trays.

While the PLUS technology will not prevent a tray from blowing dry, it does help offset the efficiency losses that occur because of high entrainment in low liquid rate services. Gains of 5% in useable (efficient) capacity are typical.

The PLUS technology is installed below each tray and helps reduce the entrainment of liquid droplets from one tray to the next.

The deentrainment device is a customized design that typically uses a specifically designed FLEXIPAC® structured packing. Because structured packing is used, this technology typically is not applied in fouling services.

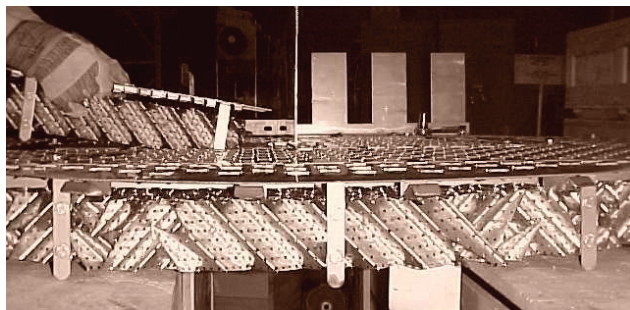

Overview

- Diameters from 3 ft [900 mm]
- Applications with low liquid rates
- Available with most downcomer designs

Construction Details

- Fits most SUPERFRAC tray configurations
- Designs for specific application requirements
- Installed below tray deck
- FLEXILOCK construction

Design Options

- Valve options: VG-0, VG-10, PROVALVE, MV-1, and CRV
- Optimized liquid push
- Bubble promoters for applicable liquid rates
- Proprietary design techniques
- Bolted design

Application - EDC Heavy Ends Column Revamp

A Vinyl Chloride Monomer producer wanted to revamp its EDC Heavy Ends column to achieve a significant capacity increase and eliminate frequent shutdowns because of tray fouling. Simulations of the operating data, evaluation of the tray hydraulics, and a gamma scan of the column revealed that the existing sieve trays were at their operating limit.

The column upgrade included:

- Replacing the sieve trays above the feed with SUPERFLUX trays on the same 15 in [381 mm] tray spacing.
- Increasing tray spacing below the feed from 15 in [381 mm] to 18 in [457 mm] without welding in new tower attachments.
- Adding a transition tray below the feed to mix the internal reflux with the liquid in the feed and then distribute it to the 2-pass trays below.
- Using expansion tray rings and special downcomer adapters to support the new SUPERFLUX trays and eliminate field welding to the vessel wall.

During the test run, the target design rate of 110% was met at the midpoint of the first day with a target purity of 99.6% EDC in the overhead product stream. The product specification for the 1,1,2 Trichloroethane impurity in the overhead was also met.

Even though three trays were eliminated in the column because of increased tray space, the required product purities were achieved at the same reflux rate.

The column has operated at 124% of original capacity over a two-year period and has not lost operation time because of tray fouling. A comparison of the column's performance before and after the revamp is shown in the table below.

	Before Revamp	After Revamp
Feed Rate, gpm	327	406
OVHD Product Rate, gpm	310	385
OVHD EDC Purity, wt%	99.60	99.61
OVHD Temperature, °F	221	236
Bottom Temperature, °F	250	252 - 257
Column Pressure Drop, psi	9.0	8 - 9.5
Capacity	100%	124%
Reflux Ratio (L/D)	0.48%	0.45 - 0.52%

Applications

SUPERFRAC® trays can be used in new construction and revamp opportunities for virtually any service in which conventional sieve and valve trays are used. They are especially beneficial in applications requiring a large number of mass transfer stages, or where mass transfer efficiency is critical to the economics of the operation. Examples include superfractionators (ethylene, propylene); light hydrocarbon fractionators; and splitters in chemical, petrochemical, and aromatics applications.

Depropanizer Revamp with Two Types of SUPERFRAC® Trays

In 1990, the sieve trays in the rectifying section were upgraded and the stripping section trays were replaced with INTALOX® structured packing to increase the capacity from 4,000 barrels per day to 6,000 barrels per day.

In 2000, the operator wanted to increase the capacity again. At that point, the sieve trays in the rectifying section were the limitation. These trays were replaced with conventional and truncated downcomer SUPERFRAC trays.

The column now handles a maximum feed rate of 7,100 barrels per day. Upstream equipment, and not the column internals, now limits the capacity of the column. The next limitation in the column will most likely be the structured packing.

A post-revamp performance test indicates that the SUPERFRAC trays in the rectifying section are operating with tray efficiencies in excess of 100%.

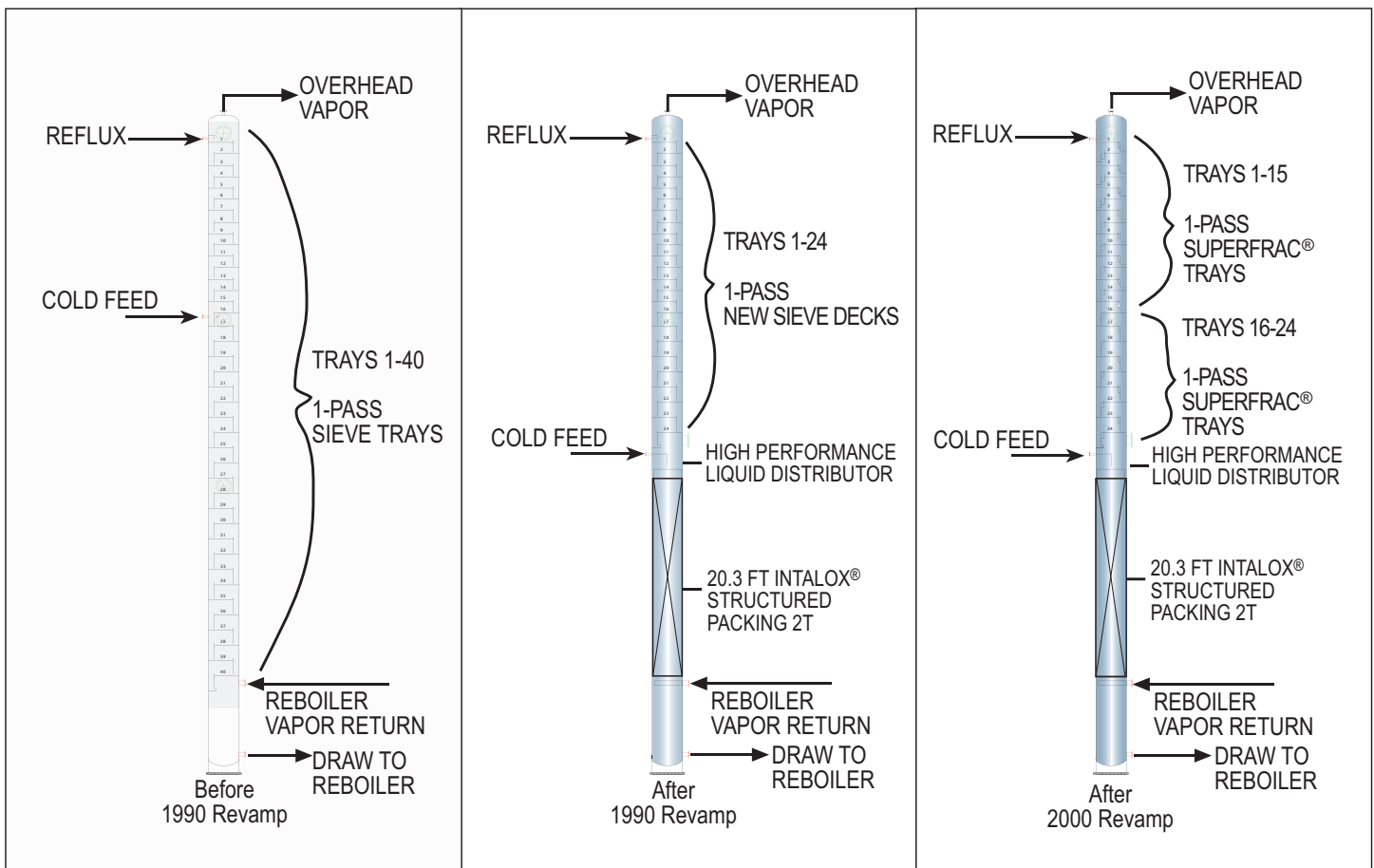

Column Layouts Before and After Revamps

C₃ Splitter Revamp with Multi-chordal, Multi-pass SUPERFRAC® Trays

A significant revamp of a C₃ splitter unit was completed in 2000 to obtain additional capacity over first generation high capacity trays. Because of the number of stages involved in this propylene / propane separation, the splitter is actually two columns. The feed is to the middle of the lower column, which has both a stripping and a rectifying section. The upper column contains additional rectifying trays. A simplified process flow diagram of the unit is shown below.

The tray design changes included SUPERFRAC style downcomers to maximize active area, push valves, fixed MINIVALVE units, higher open area, reduced weir height, number of passes increased to six, and tray space increased below the feed.

OMNI-FIT® revamp techniques were used to change the number of passes and tray spacing without welding to the column shells. In addition, the feed inlet nozzle was relocated to a higher position on the column.

Even with the 6-pass design and reduced flow path length, the overall tray efficiency was still measured in the 90% to 95% range. The end result was a 17% increase in propylene production with no loss of fractionation efficiency.

	Before	After
Diameter, ft	16	16
Tray Configuration	4-Pass	6-Pass
Tray Type	1st Generation High Capacity Trays	Multi-Chordal SUPERFRAC Trays
Deck Type	Movable Valves	VG-0
Above Feed		
Number of Trays	196	178
Tray Spacing, inches	22	22
Below Feed		
Number of Trays	44	49
Tray Spacing, inches	22	27.5
Propylene Rate, MM lb/yr	820	958
Max wt% Propane Overhead	0.4%	0.4%
Max lv% Propylene Bottoms	5.0%	5.0%

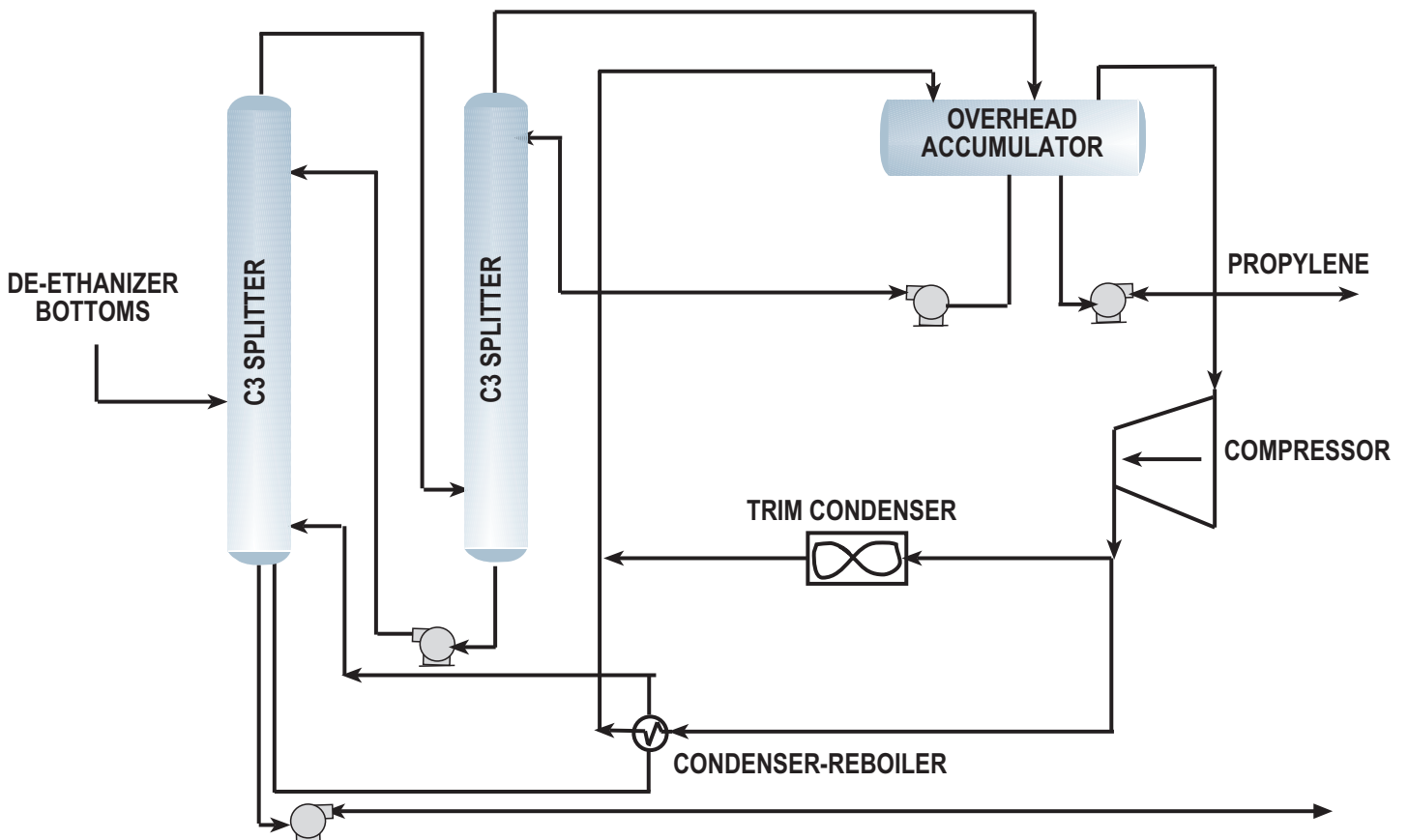

C₃ Splitter Simplified Process Flow Diagram

Construction Details

Metal

Trays are available in any formable, weldable sheet metal material. The most common materials for trays are:

- Carbon steel
- Stainless steel, ferritic, austenitic, duplex, martensitic
- Nickel alloys
- Copper alloys
- Titanium, zirconium

Trays are not normally stress relieved or annealed and typically do not conform to pressure vessel standards.

Trays fabricated from sheet metal materials are typically supplied in “as-sheared” condition.

Bolting

Standard bolting conforms to AISI specifications. Bolting conforming to ASME® specifications is available upon request.

Certification

Material certification is available for all fabricated internals. Positive Material Identification (PMI) testing is available upon request.

Gasketing

For multi-piece trays requiring gasketed joints, many choices of gasket material are available. Where gasketing is required, braided fiberglass tape is supplied as the standard for linear joints. Depending on the service, KLINGERSIL® C-4401, expanded PTFE, or spiral wound stainless steel with flexible graphite filler gaskets are supplied as the standard for flanged connections. Other gasket materials are available upon request.

Manway Access

All trays are designed in sections to pass through vessel manways. Tower internals are designed to pass through a vessel manway of 18 in [450 mm] minimum inside diameter, unless otherwise specified. Larger manways often provide the ability to optimize the design of components for faster, easier installation. Please provide manway locations and inside diameters at the time of inquiry.

Scope of Supply

For the trays in this brochure, Koch-Glitsch supplies all removable parts.

The trays do not include vessel attachments for connection or support, unless specifically stated in the item description. Vessel attachments may be quoted/supplied separately. Examples of attachments that may be required are:

- Support rings
- Sump frames
- Internal flanges at feed inlet nozzles
- Wall clips for support
- Downcomer clamping bars
- Beam seats

Minimum Support Ring Widths

All dimensions are expressed as inches [millimeters]

Tower ID	Trays Clamped to a Support Ring
Below 27.5 [Below 700]	Typically supplied as cartridge tray construction; trays require a vessel body flange for installation.
27.5 - 59.0 [700 - 1500]	1.5 [40]
59.1 - 98.4 [1501 - 2500]	2.0 [50]
98.5 - 137.8 [2501 - 3500]	2.5 [60]
137.9 - 177.2 [3501 - 4500]	3.0 [70]
177.3 - 236.2 [4501 - 6000]	3.5 [90]
236.3 - 295.3 [6001 - 7500]	4.0 [100]
295.4 - 354.3 [7501 - 9000]	5.0 [120]
If support ring size is other than those listed above, special consideration must be given to the plate diameter and vessel tolerances.	

Feed Devices

Obtaining desired tower performance requires the proper handling of liquid and vapor entering the column. The types of feeds or inlets into a column can generally be classified into three major categories:

- Liquid only (contains less than 1% of vapor by volume)
- Mixed liquid and vapor, flashing or suppressed flash
- Vapor

Liquid-Only Feeds

Among the factors that Koch-Glitsch engineers consider when designing a liquid feed device are:

- Type of tray
- Expected tray performance
- Flow rate
- Operating range
- Degree of sub-cooled liquid
- Requirements for mixing

Liquid-Vapor and Flashing Feeds

For mixed liquid-vapor or flashing feed devices above a tray, the selection depends on:

- Tray type
- Liquid and vapor flow rates
- Turndown
- Column height needed for disengagement and vapor distribution
- Requirements for mixing

In all cases, separating the vapor and the liquid phases is a primary concern. In some cases, the requirements for additional pre-distribution may alter certain tray designs.

Vapor-Only Feeds

Two factors must be considered when choosing the proper device for a vapor-only feed.

- The kinetic energy of the inlet vapor in relation to the pressure drop across the trays, the feed nozzle arrangement, and the tower separation requirements.
- If there is a large difference in the composition and/or temperature between the inlet vapor stream and bulk vapor flow, mixing the two vapors optimizes the performance of the trays.

Specific equipment for vapor distribution may not be required if sufficient column height is available for equalization or if the pressure drop across the trays is sufficient to provide proper vapor distribution.

Selection Criteria

The selection criteria for each category of feed device is unique. Please consult with a Koch-Glitsch technical representative for recommendations.

CFD Modeling

Good vapor distribution is essential to achieve superior separation efficiency. Poor vapor distribution is often a major source of problems.

Koch-Glitsch combines modern Computational Fluid Dynamics (CFD) modeling technology with its engineering expertise to analyze vapor and liquid distribution when evaluating the performance of existing equipment and developing new, improved designs. This involves computer modeling of the 3-dimensional configuration of the column internals to provide detailed predictions of fluid flow (velocity profiles and so forth) as shown in the figure below.

Koch-Glitsch offers CFD services for the following tasks:

- Development and optimization of new mass transfer equipment
- Troubleshooting or analysis of existing equipment
- Confirmation of equipment designs prior to fabrication and installation

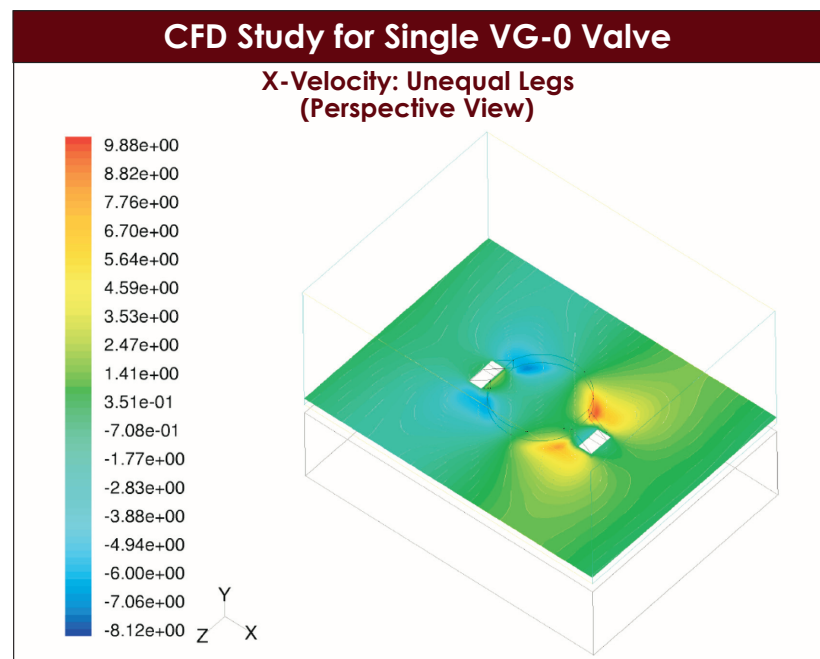

Mechanical Features

FLEXILOCK® Tray Construction

The patented FLEXILOCK® tray joint allows rapid installation of tray panels in vessel shops or in the field. FLEXILOCK tray construction eliminates the requirement for hardware between adjacent tray panels and provides for error-free deck installation. FLEXILOCK tray construction can be used to:

- Reduce hardware requirements
- Improve valve coverage
- Provide error-free deck installation
- Dramatically reduce installation time
- Strengthen joint and uplift tolerance
- Promote in-shop installations
- Cancel vibration-induced panel shifting

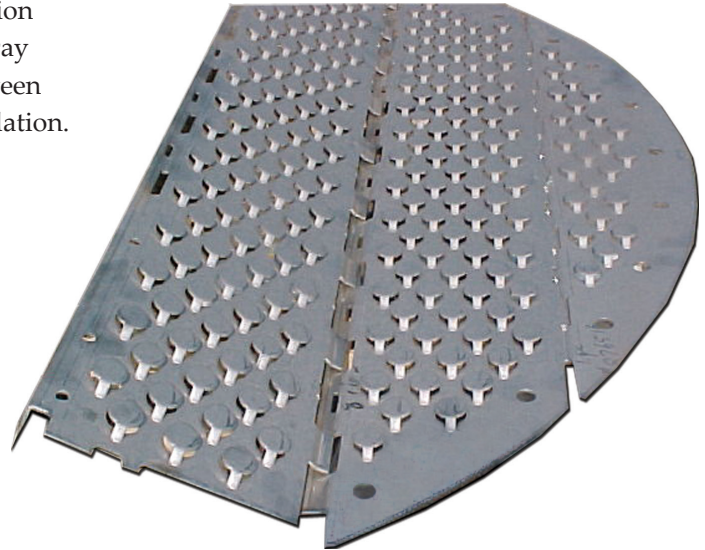

OMNI-FIT® Technology

OMNI-FIT® technology is a set of mechanical engineering designs used to reduce the cost and downtime of revamps. These technologies include expansion rings, pedestal supports, downcomer adapters, and innovative tray designs that can minimize or eliminate welding on an existing tower. Efficiency and capacity enhancements can be achieved by using OMNI-FIT technology for your next turnaround project.

OMNI-FIT technology can be used to:

- Increase theoretical stages
- Change tray spacings
- Change the number of passes
- Modify downcomer sizes or configurations
- Install multi-pass SUPERFRAC trays
- Change tray orientation
- Eliminate welding
- Shorten turnarounds
- Replace packing
- And more...

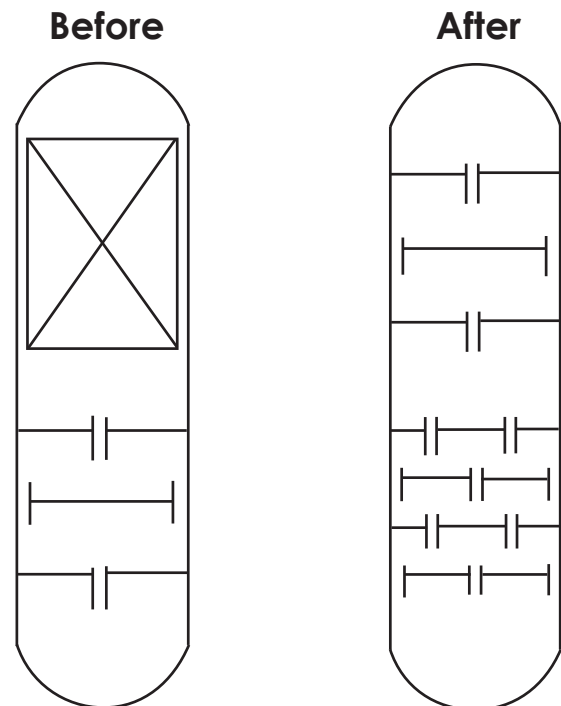

HORIZON® Technology

HORIZON® technology is a set of mechanical construction techniques developed specifically for in-shop installation of trays with the vessel in the horizontal position. The patented FLEXILOCK tray construction from Koch-Glitsch is the primary building block of the HORIZON technology. If you plan to shop-install trays, then you need the capabilities provided by HORIZON technology.

- Special mechanical design helps prevent inefficient installation sequencing, part deforming/breaking, panel shifting, joint dislodging, extra field inspecting, and field readjusting of tray parts.
- Installation in the shop versus in the field helps reduce installation costs, accommodates short turnaround schedules, and reduces space constraints involved with manhole access and off-shore platform installations.



Tray Maintenance Services

Comprehensive services for turnarounds and shutdowns.

Downtime is critical for both planned and unplanned turnarounds. Koch-Glitsch is available 24/7 to offer equipment and comprehensive support and services to get your tower up and running as quickly as possible. Our response teams are strategically located around the world and are ready to serve you at any time.

Services include:

- Inspection
- Hardware trailers and lockers
- AHOP® Automated Hardware Ordering Program
- Equipment Support Services (ESS) technicians

Combined with Koch Specialty Plant Services, Koch-Glitsch goes a step further with its ability to deliver unique, value-driven turnkey equipment and installation solutions to provide faster, safer revamps, which often result in shorter duration turnarounds.



Emergency Delivery

Emergencies happen . . .

Koch-Glitsch has a wide variety of products to provide optimum performance whatever the application. Many common materials are in stock, and equipment can be quickly manufactured to meet your requirements regardless of original equipment manufacturer.

With manufacturing facilities and warehouses strategically located worldwide, Koch-Glitsch leads the industry with its on-time performance for delivery of emergency trays and hardware, packing and internals, and mist elimination equipment.

For emergencies, call the Hotline of your nearest Koch-Glitsch office:

- In the USA and Latin America, call 1-888-KOCH-911 (mass transfer), 1-316-207-7935 (mist elimination), or your local Koch-Glitsch office.
- In Canada, call 1-905-852-3381 (Uxbridge, Ontario).
- In Europe, call +39-06-928-911 (Italy), +44-1782-744561 (UK), or your local Koch-Glitsch office.
- In Asia, call +65-6831-6500 (Singapore) or your local Koch-Glitsch office.

Koch-Glitsch Corporate Offices

Worldwide Headquarters

Koch-Glitsch, LP

4111 East 37th Street North | Wichita, KS 67220 - United States | tel: (316) 828-5110 | fax: (316) 828-7985

Europe

Koch-Glitsch Italia S.r.l.

Via Torri Bianche, 3A | 20871 Vimercate MB - Italy | tel: +39-039-6386010 | fax: +39-039-6386011

Asia

Koch Chemical Technology Group Singapore Pte. Ltd.

260 Orchard Road, #11-01/09
The Heeren | Singapore 238855 | tel: +65-6831-6500 | fax: +65-6835-2031

Koch-Glitsch (a division of Koch Chemical Technology Group India Pvt. Ltd.)

10th Floor, Corporate Park II
Sion-Trombay Roa | Chembur, Mumbai 400 071 - India | tel: +91-22-6771-7171 | fax: +91-22-6771-7161

For a complete list of our offices and facilities, visit us on the Web at www.koch-glitsch.com.



Emergency Numbers

United States/Latin America: 1-888-KOCH-911 (mass transfer), 1-316-207-7935 (mist elimination),
or your local Koch-Glitsch office.

Canada: 1-905-852-3381 (Uxbridge, Ontario).

Europe/Middle East/Africa: +39-06-928-911 (Italy), +44-1782-744561 (UK),
or your local Koch-Glitsch office.

Asia: +65-6831-6500 (Singapore) or your local Koch-Glitsch office.

Trademarks

The following registered trademarks are owned by Koch-Glitsch, LP in the United States and may be registered in other jurisdictions: AHOP® Automated Hardware Ordering Program, FLEXILOCK® tray construction, FLEXIPAC® structured packing, HORIZON® technology, INTALOX® structured packing, KOCH-GLITSCH® technology, "K" KOCH-GLITSCH (logo), MINIVALVE® tray, OMNI-FIT® technology, PROVALVE® tray, SUPERFLUX® tray, SUPERFRAC® tray and ULTRA-FRAC® tray. The following trademarks are owned by Koch-Glitsch, LP in the United States and may be registered in other jurisdictions: KITTEL tray, PLUS technology, PURGE downcomer, and YOU CAN RELY ON US. All other trademarks, service marks, or registered trademarks that appear in this document are the trademarks or service marks of their respective owners.

For related trademark information, visit <http://www.koch-glitsch.com/trademarks>.

Patents

The following technologies are protected by one or more patents in the USA; other foreign patents may be relevant: FLEXILOCK® tray construction (US6592106), KITTEL trays (US7028995), Mini Bubble Promoter (USD650466), OMNI-FIT® technology (US6736378, US7055810, US7125005), PLUS technology (US5762668), PROVALVE® tray (US5762834), SUPERFLUX® tray (US5895608), and SUPERFRAC® tray (US5762668, US5895608, US5632935).

Legal Notice

The information contained in this bulletin is believed to be accurate and reliable, but is not to be construed as implying any warranty or guarantee of performance.

