

SEVERE SERVICES

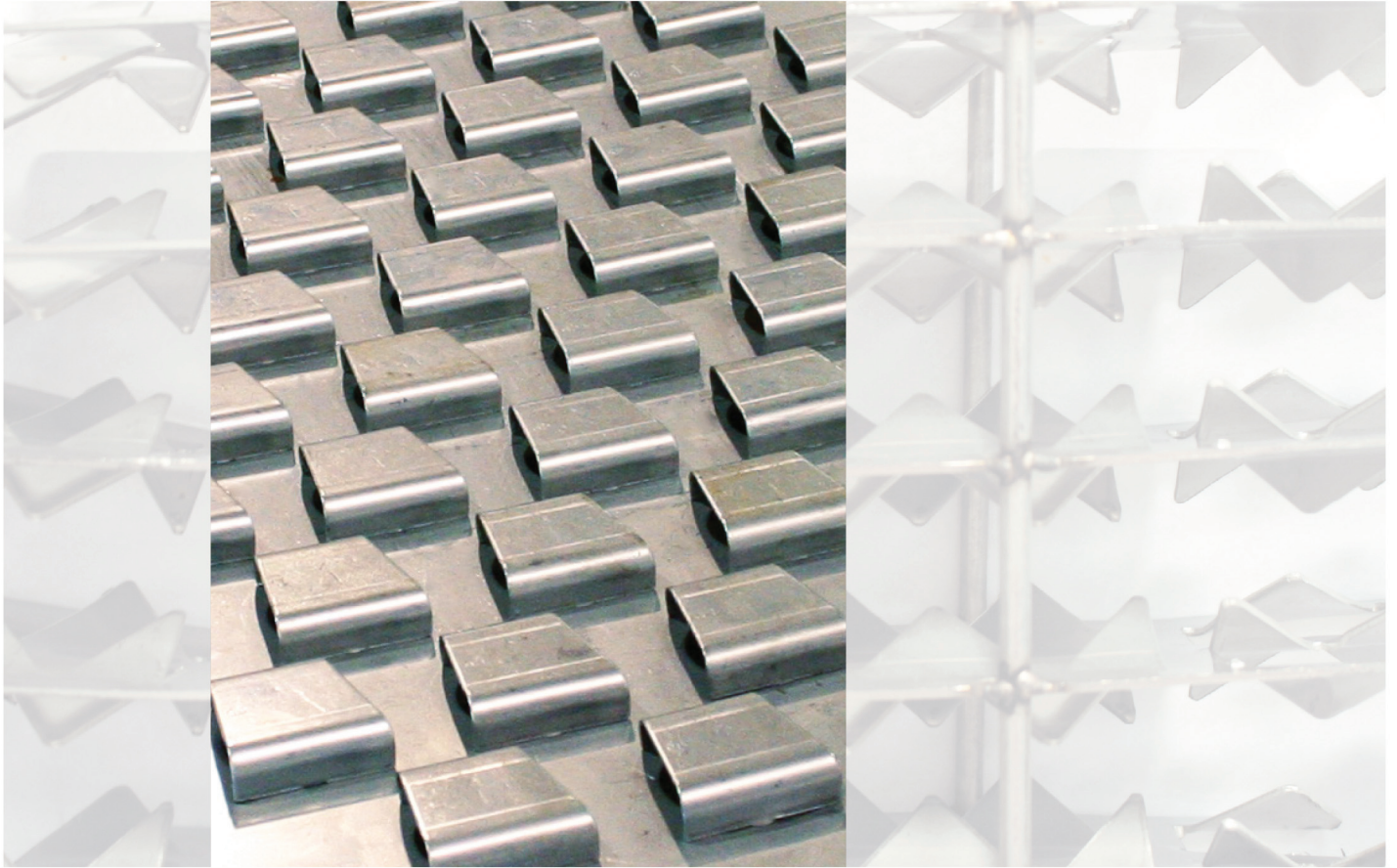

YOU CAN RELY ON US.

K KOCH-GLITSCH®

Severe Services

Koch-Glitsch is a leader in advanced technology, equipment and tower designs for reliable unit operations in severe conditions.

Many refining separation processes as well as several petrochemical and chemical processes are subject to severe operating conditions. Koch-Glitsch has extensive knowledge and experience in the design of tower internals for conditions such as fouling, coking, erosion, corrosion, vibration and frequent upsets. To apply the appropriate technologies, Koch-Glitsch engineers work with each client to obtain the specific characteristics of the application that must be addressed.

Fouling Mechanisms

Proper design of internals for severe services requires identifying the potential for the severe conditions and then developing a clear understanding of the nature or cause of the problem. Modifying the operating conditions or the process scheme may help minimize the potential hazard. For severe conditions that cannot be eliminated, appropriate equipment designs can provide longer run times.

Known fouling mechanisms include solid particles (such as pipe scale), coking, salt depositions, polymerization, and decomposition.

To minimize the formation of this type of fouling:

- Column operating conditions (temperature, pressure, etc.) should be carefully reviewed and optimized
- Proper wetting of the mass transfer equipment can help keep the equipment flushed clean.
- Proper equipment design can help minimize fouling accumulation.

Processes where solids enter the column with the vapor or gas stream can experience an erosion problem for the equipment directly exposed to the vapor stream, in addition to fouling.

Not all solids behave in the same manner inside the column. Solids in crystalline form are often easily removed with sufficient liquid flow. Other solids, such as coke and polymers, once formed, will stick to the mass transfer device and will grow. Performance (capacity, pressure drop and efficiency) of the equipment deteriorates over time as the amount of solids accumulates. Eventually, a column shutdown is required to clean or replace the fouled equipment. In this event, trays often allow greater access for cleaning and may require less shutdown time.

Corrosion

Corrosion problems can often be properly corrected with careful equipment material selection. Packed bed systems subject to corrosion must also allow for heavier gauge material designs than conventional packings which offer no allowance for corrosion. Grid type packings or trays are often a better option as they are fabricated from much thicker materials and can more easily accommodate a corrosion allowance with minimal impact on process performance.

Column Upsets

The operating conditions of some columns contain a high risk for upsets or surges. Crude oil distillation columns with stripping steam can be subject to frequent upsets. The presence of any liquid water can result in a massive expansion of the volumetric flow upon vaporization. This can create an upset force capable of damaging the tower internals, which will reduce or severely degrade equipment performance.

Proper startup, shutdown and operating procedures are the best defense in eliminating equipment damage caused by upsets. Because the risk of accidental upsets cannot be completely eliminated, the use of packings and grids is often a good choice. The extremely high open area of these devices (compared to trays) allows the packing to better handle a sudden increase in vapor rate. A full range of heavy-duty tower internal designs to increase the mechanical integrity of the equipment and allow for improved unit reliability is available from Koch-Glitsch.

Trays

Koch-Glitsch offers a complete range of tray designs to address fouling and upset conditions.

In addition to standard baffle trays, disc and donut trays, shed rows and dual flow trays, Koch-Glitsch offers tray solutions that combine improved process performance with high resistance to fouling and upsets. Large diameter fixed valves, such as the patented PROVALVE® unit or the VG-10 valve, can be used to reduce the tendency to foul in moderate fouling systems. For extreme fouling services, Koch-Glitsch employs the capacity and efficiency features of the SUPERFLUX® tray to increase run time.

SUPERFLUX® Tray

For extreme fouling services, the SUPERFLUX® tray provides increased fouling resistance, which can lead to increased run times. Several valve options are available that promote self-cleaning of the active areas. These valves have directional components that use vapor energy to provide a forward-lateral push to the froth. This action is critically important to maintain proper tray activity and reduce residence time of solids on the tray deck.

Particular attention is paid to the peripheral areas of the deck where stagnation may lead to solids deposition. Directional valves are placed in this area to both increase bubbling activity as well as promote a uniform flow profile. These components combine to reduce the residence time distribution and enhance the fouling resistance of the trays.

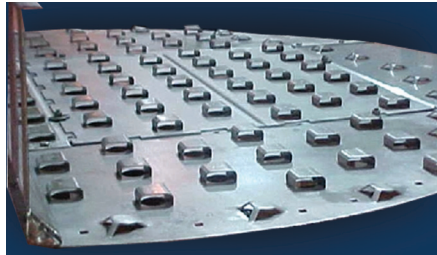

SUPERFLUX® tray.

To ensure the appropriate technologies are applied for each SUPERFLUX tray design, Koch-Glitsch engineers work with each client to obtain the specific characteristics of fouling that must be addressed. Features suitable for the specific application are combined into a final design to produce a tray capable of longer run times between cleaning shutdowns.

Conventional Downcomers

SUPERFLUX trays with conventional downcomers use active area enhancements and may have an improved inlet area. The straightforward design of the downcomers allows the use of standard tray construction.

This type of tray design is suitable for processes that are particularly prone to active area fouling, such as sour water strippers and bioethanol beer stills.

PURGE Downcomers

In processes where downcomer fouling causes frequent shutdowns and where conventional downcomers do not provide the optimum design, Koch-Glitsch recommends the PURGE downcomer configuration.

The PURGE downcomer has proven suitable to resist fouling for very severely fouling applications such as polymer slurry, acrylonitrile, and butadiene.

Characteristics

- Diameters from 3 ft [900 mm]
- Fouling resistant with fixed valves
- Conventional downcomer design allows simple revamps
- PURGE downcomer design is the ultimate solution for sediments
- Directional valves promote self-cleaning of active area

Construction Details

- Conventional style downcomers that are either straight or sloped
- PURGE downcomers for very severe services
- Custom-engineered designs for specific applications
- FLEXILOCK® tray construction

Design Options

- Valve options: VG-10, PROVALVE®
- Proprietary design techniques
- Bolted design
- Electropolishing

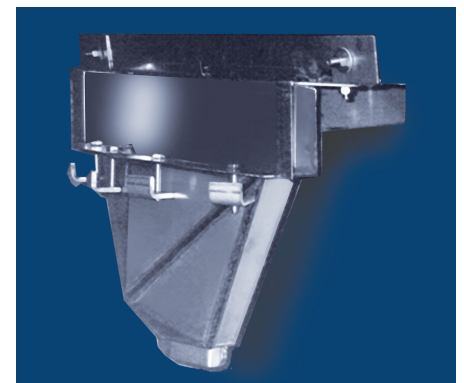

PURGE downcomer.

PROVALVE® Tray

The PROVALVE® tray offers the wide operating range of conventional valve trays, but with no moving parts. The valve design prevents valve leg or deck wear and eliminates the potential for popped, fouled, or stuck valves.

The key to the fouling resistance of the PROVALVE tray is its tapered valve cover, which imparts a forward-lateral push to the liquid flowing across the tray. This directional flow keeps the liquid moving uniformly across the deck, sweeping the deck clean of orifice-clogging debris.



PROVALVE® unit.

The directional flow of the PROVALVE tray also provides uniform liquid and vapor distribution across the entire tray with a low, even spray height across the deck. This increases the tray's efficiency, prevents liquid backflow, suppresses jet flooding, and permits operation at greater vapor rates.

The sheltered valve design is more resistant to liquid weeping through the deck orifices. The large open area protects against vapor surges and promotes lower pressure drop with a wide operating range. These actions provide a turndown capability that is not achievable with sieve trays or other types of fixed valve trays.

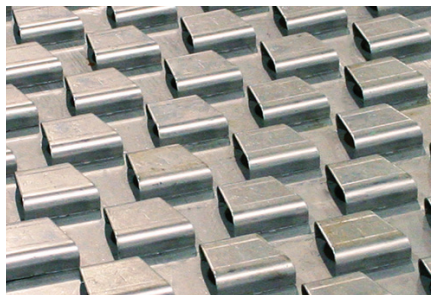

PROVALVE® tray.

The valve lift of a fixed valve that is extruded from the tray deck is dependent on the metal's ability to be stretched. The PROVALVE unit cover is designed to allow clearances in excess of 0.5 in [12.7 mm] even on trays made from difficult-to-form materials such as Superduplex steels or brittle materials like titanium and zirconium.

The PROVALVE unit is also available in fluoroplastics and graphite for highly corrosive applications where a suitable metallic material is not available.

PROVALVE trays are used in a wide variety of services – from severely fouling refinery applications to petrochemicals to fine chemical separations.

Characteristics

- Higher capacity than full-size valve trays
- Maximum opening size for maximum fouling resistance
- Longest up time between shutdowns
- Fixed opening so valve cannot stick shut
- High weepage resistance for a wide operating range
- Easy to clean; less downtime
- Rugged, durable construction for long tray life
- FRI tested

Construction Details

- Conventional style downcomers that are either straight or sloped
- FLEXILOCK® tray construction

Design Options

- Bolted design
- Shear clips
- Explosion doors
- Electropolishing



PROVALVE® tray in PTFE material for highly corrosive applications.

VG-10 Fixed Valve Tray

The VG-10 fixed valve tray is an economical choice for moderate to severely fouling applications.

The VG-10 valve is a full-size fixed valve that is anything but conventional. The valves can be punched in materials up to 0.25 in [6.35 mm] thick for maximum resistance to corrosion. The net rise (vertical opening) typically ranges from 0.236 in [6 mm] to 0.551 in [14 mm].

The large net rises available plus the directional liquid flow make this an outstanding anti-fouling valve.

- A large net rise helps to ensure that large particles can freely pass through the deck openings.
- The valve is directional with the rear leg being visibly wider than the downstream front leg. The liquid push is strong enough to help solid material to be flushed downstream and toward the downcomer where it can exit off the tray deck.

There are no protrusions below the deck for material to hang up on, which is useful for applications where the fouling mechanism is primarily on the underside of the tray deck or by polymerization in the vapor phase.

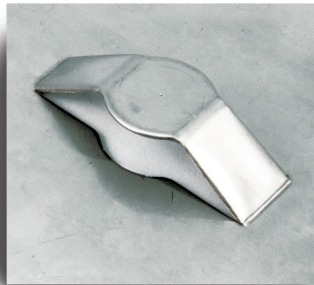

VG-10 valve.

Characteristics

- Large openings for improved fouling resistance and extended run length
- Fixed opening prevents valves from sticking to deck or spinning
- Easy to clean; less downtime
- Rugged, durable construction for long tray life
- Large net rise allows large particles to pass through easily
- Strong directional liquid flow to push solid materials downstream
- No protrusions below the deck to trap particles or for deposits to grow

Design Options

- Bolted design
- Shear clips
- Explosion doors
- Electropolishing

SUPERFLUX® and PROVALVE® Trays in Fouling Applications

Shown to the right are conventional valve trays used in a butadiene application. After one year of operation, the conventional trays are severely fouled by poly-butadiene “popcorn” polymer. After one year of operation following a revamp to SUPERFLUX trays (right), the trays remained polymer free.



Conventional trays show severe fouling.



SUPERFLUX® trays are polymer free.

In a comparison of 0.5 in [12.7 mm] sieve trays and PROVALVE trays in a severely fouling refinery sour water stripper, the PROVALVE trays have achieved a run time exceeding 3 years, over six times longer than the original sieve trays.



Sieve trays are more than 90% plugged after 5 months.



PROVALVE® orifices show little signs of fouling after 5 months.

Severe Service Grid Packing

Koch-Glitsch offers a wide variety of grid type packings that provide additional resistance to fouling, upsets and erosion.

The wide variety of grid type packings available from Koch-Glitsch are characterized by greater material thicknesses compared to structured packing and welded construction. These features provide additional fouling resistance, protection against upset, and reduced impact of erosion for demanding conditions.

High Capacity and Low Pressure Drop

Grid packings have an extremely high open area and thus provide higher capacity and lower pressure drop than other packings or trays. As a result, grid packings are used in pumparounds of refinery fractionator vacuum columns to increase throughput and minimize column pressure drop.

Fouling and Coking Resistance

Blades of grid packing are bent out at an angle from the vertical to induce turbulent contact between the rising vapors and descending liquid. There are no horizontal surfaces on the packing, so the packing can drain freely preventing liquid and solids from collecting. This minimizes liquid residence time (or liquid holdup), which reduces the potential for coking.

Coking in the wash zone of refinery fractionators (as well as polymerization in many other refinery and petrochemical applications) is often caused by dry-out due to vaporization from under-irrigated packing. Adequate wetting of the packing is required to ensure that the packing is continually flushed clean and to avoid hot spots caused by drying of the packing. This will also allow the removal of particles that can otherwise collect and begin the formation of coke at high temperatures. The low surface areas of grid packings allow for excellent wettability at low liquid rates – meaning that the packing can remain adequately wetted at lower liquid rates. The large blade spacing provides large flow channels through the grid so solid particles can pass through more easily.

Corrosion and erosion resistance

The standard thickness of grid packings is 7 to 15 times thicker than conventional sheet metal structured packings and 3 to 5 times thicker than a typical random packing. This increased packing thickness gives the packing a significantly greater life in corrosive and/or erosive systems.

Upset resistance

Both the increased packing thickness and welded construction provide a rigid framework that makes the packing very strong and resistant to damage during upsets. The top three layers of the grid are normally "J"- bolted together for increased mechanical strength. No other retaining device is usually required because of the high open area and low pressure drop grid packing. When additional uplift protection is required, the entire grid packing bed can be held together with through rods to form a continuous structure that is highly resistant to mechanical damage and upset.

Materials of Construction

- Carbon steel
- Stainless steels, including austenitic, ferritic, martensitic; types 410/430, 304, 316 and 317 are readily available
- Duplex stainless steels
- Nickel alloys

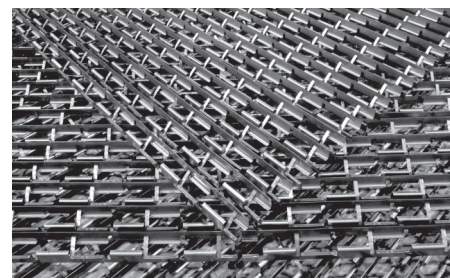

GLITSCH-GRID EF-25A grid packing.



PROFLUX® Severe Service Grid Packing

The patented PROFLUX® severe service grid combines the efficiency of structured packing with the robustness and fouling resistance of grid packing. It outperforms both of its predecessors in severe services.

The combination of rugged welded rod assembly and sturdy corrugated sheets of increased material thickness provides a very robust design that resists damage because of tower upsets or erosion.

The spacing between the sheets eliminates areas where solids could collect and provides improved fouling resistance.

Physical Characteristics

Packing Size	45	64
Specific surface area	45 m ² /m ³	64 m ² /m ³
Bulk density	160 kg/m ³	230 kg/m ³
Panel length	1524 mm	1524 mm
Panel width (center to center)	371 mm	340 mm
Panel height	138 mm	138 mm
Element rotation	60°	60°

Characteristics

- Improved fouling resistance
- Better efficiency and de-entrainment
- Superior durability
- Reduced installation and removal time
- Easy removal for cleaning

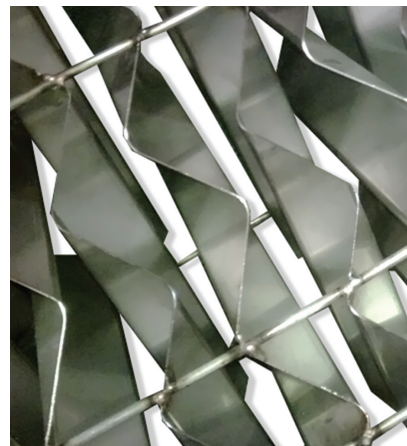

FLEXIGRID® and GLITSCH GRID® Severe Service Grid Packing

FLEXIGRID® and GLITSCH-GRID® severe service grid packings provide reliable service in many demanding applications.

FLEXIGRID structured packing has two styles: 2-45 and 3-45.

- Style 2-45 is optimized for maximum capacity, low liquid holdup, and minimum pressure drop. It provides the greatest fouling resistance.
- Style 3-45 provides improved efficiency because it has a larger projected area perpendicular to the gas flow causing more turbulent gas flow.
- Other configurations with higher or lower surface area are available.

GLITSCH GRID EF25A structured packing was one of the first grid packings ever applied and is still widely used in refineries around the world.

Physical Characteristics

Packing Size	2-45	3-45	EF-25A
Specific surface area	45 m ² /m ³	45 m ² /m ³	37 m ² /m ³
Bulk density	259 kg/m ³	259 kg/m ³	242 kg/m ³
Panel length	1524 mm	1524 mm	1524 mm
Panel width (center to center)	400 mm	400 mm	381 mm
Panel height	70 mm	70 mm	54 mm
Element rotation	45°	45°	45°

Characteristics

- Reliable operation in severe services
- Heavier gauge material than conventional structured packing
- Superior durability

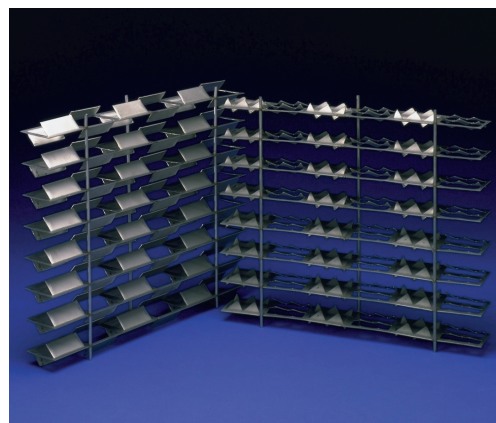

FLEXIGRID® severe service grid packing. Style 3-45 (left). Style 2-45 (right).

FLEXIPAC® S Structured Packing

FLEXIPAC® S structured packing uses a smooth metal packing surface as opposed to conventional FLEXIPAC packing, which can employ various surface textures. The removal of the surface texturing eliminates the small areas on the packing surface where fouling can begin.

FLEXIPAC S packing is suitable for moderately fouling applications but does not provide the same reliability and fouling protection as the PROFLUX®, FLEXIGRID® and GLITSCH GRID® packing product lines.

FLEXIPAC S structured packing is available in heavier gauge material than conventional FLEXIPAC packing to provide improved corrosion and/or erosion resistance.

Characteristics

- Smooth surface
- Moderate fouling applications
- Heavier gauge material than conventional FLEXIPAC® structured packing

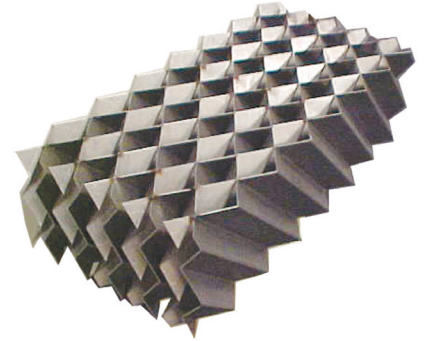

Physical Characteristics

Packing Size	4Y/4X	3.5Y/3.5X	3Y/3X	2.5Y/2.5X
Specific surface area	55 m ² /m ³	80 m ² /m ³	110 m ² /m ³	155 m ² /m ³
Bulk density	66 kg/m ³	96 kg/m ³	88 kg/m ³	124 kg/m ³
Element height	268/285 mm	265/285 mm	267/286 mm	264/283 mm
Element rotation	90°	90°	90°	90°

Packed Tower Internals for Reliable Unit Operation

Model 622 Trough Style Liquid Collector

The Model 622 trough collector is specifically designed for liquid collection below a packed bed in applications where liquid hold-up must be minimized to avoid coking or fouling.

It is the preferred design for the overflow collector tray in deepcut crude vacuum towers.

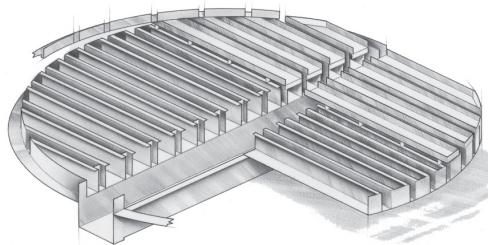

Characteristics

- Sloped construction reduces residence time and minimizes coking
- High open area minimizes pressure drop
- Emergency overflow
- Thermal expansion without excessive leakage

Model 985 Trough Distributor with Weirs

The weir trough distributor is specifically designed for applications with severe fouling conditions and high liquid flow rates. It is well suited for applications where the liquid contains solid particles. This distributor is widely used in the slurry pumparound zone of FCC main fractionators.

Liquid discharges to the packing from large slots in the troughs that are arranged in a uniform pattern across the tower cross sectional area at a typical pour point density of 2 - 4 points/ft² [20 - 40 points/m²]. The vertical slots provide improved flow distribution compared with V-notches. The V-notches provide free passage of solids if the slots become blocked.



Model 943 Spray Nozzle Distributor

Spray nozzle distributors are primarily used in refinery applications where good liquid coverage and complete wetting of the bed is necessary and for heat transfer. In refinery fractionators, they are commonly used in scrubbers and in the wash and pumparound zones. In heat transfer applications, the liquid spray cone created by the distributor enhances heat transfer by providing contact with the rising vapor before the liquid reaches the packing.

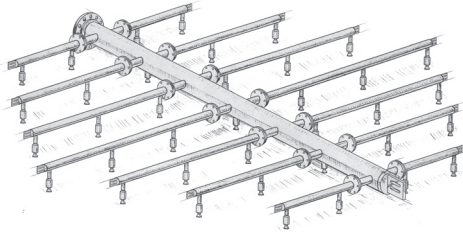

Characteristics

- Maximum free passage nozzle to resist plugging
- Optimum liquid coverage to prevent dry spots on packing that could coke
- Minimum droplet entrainment through careful inlet nozzle selection
- Elimination of dead zones in piping where liquid can stagnate

Model 758 Enhanced Vapor Horn

Vapor horns are designed to provide both bulk phase separation of the vapor and liquid as well as initial distribution of the feed vapor. These devices have been used primarily for two phase inlets of refinery fractionators. Performance of the feed inlet device is critical to ensure adequate gas oil quality and yield, maximum column capacity, and proper wash bed performance. Koch-Glitsch's proprietary enhanced vapor horn technology provides improved vapor distribution and deentrainment of the feed.

For vapor/liquid phase separation, the open bottom construction and the centrifugal action induced to the feed stream will direct entrained liquid particles to the column wall so they can flow down.

Koch-Glitsch has hundreds of commercial installations of this technology in columns with diameters up to 50 ft [15 m].

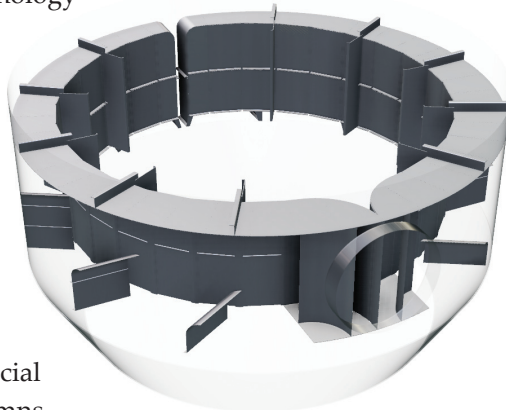

Characteristics

- Turning vanes in a proprietary arrangement to avoid excessive impingement and feed splashing, which reduces the amount of liquid entrainment
- Anti-swirl baffles to reduce cyclonic motion of the vapor
- Tapered horn to meter incoming vapor proportionally to the tower cross section
- Available in tangential and radial type inlet arrangements as well as multiple feeds

Model 798 Vapor Distributor for FCC Main Fractionator

This device provides distribution of vapor feeds that are subject to extreme fouling conditions. The high velocity feed to the FCC main fractionator is very hot, which can lead to bed dry out and coke ball formation in the packed bed. The feed also contains catalyst fines from the FCC reactor that can cause erosion. This special vapor distributor is designed to withstand the high temperatures and erosive environment.

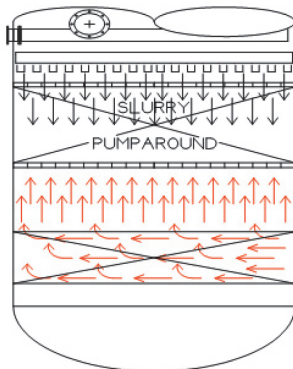

Characteristics

- Free of horizontal surfaces that allow liquid to collect
- Mitigates vapor maldistribution of feed gas to slurry pumparound bed
- Withstands severe conditions over a long period of time
- Distribution quality validated by commercial experience and CFD modeling

CFD modeling services

Good vapor distribution is essential to achieve superior separation efficiency. Poor vapor distribution can be a major source of coke formation resulting in frequent unit shutdowns.

Koch-Glitsch uses modern Computational Fluid Dynamics (CFD) modeling technology to analyze the performance of existing equipment and to develop new improved designs. This involves computer modeling of the three-dimensional configuration of the column internals to provide detailed predictions of fluid flow (e.g. velocity profiles). A commercially available CFD software package is used in conjunction with expertise developed by Koch-Glitsch to analyze vapor and liquid distributors as well as tray and packing performance.

Koch-Glitsch offers CFD services for the following tasks:

- Confirmation of equipment designs prior to fabrication and installation
- Troubleshooting or analysis of existing equipment
- Development and optimization of new mass transfer and mist elimination equipment

CFD Feed Inlet Optimization

A CFD study was used to help determine the optimum feed inlet design of a 29.5 ft [9.0 m] diameter Crude Vacuum Tower. Three different designs were modeled for the study:

- Model 768 YORK-EVENFLOW vane inlet device
- Model 758 Enhanced Vapor Horn with radial inlet
- Model 758 Enhanced Vapor Horn with tangential inlet

The entire flash zone design was modeled as a complete system and included the design of the overflash collector tray to predict the vapor distribution to the bottom of the wash bed. No single device offered a pressure drop advantage. The calculated pressure drop across all three devices was essentially the same (within 0.27 in WC [0.5 mm Hg] of each other).

The feed particle paths and velocity profiles in a number of different planes were carefully studied to determine the design having the best vapor distribution and estimated de-entrainment efficiency.

In this particular case, the enhanced vapor horn with the radial inlet nozzle produced the most uniform velocity profile to the wash bed and was selected as the optimum configuration. The improved vapor distribution from this device eliminated the need to design the overflash collector tray with an increased pressure drop to further improve vapor distribution to the packed bed.

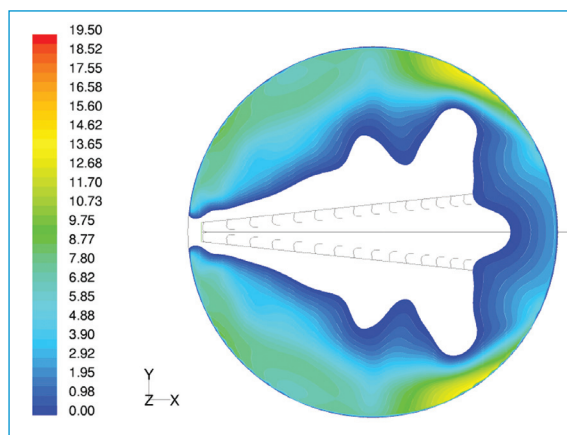

Model 768 YORK-EVENFLOW vane inlet device.

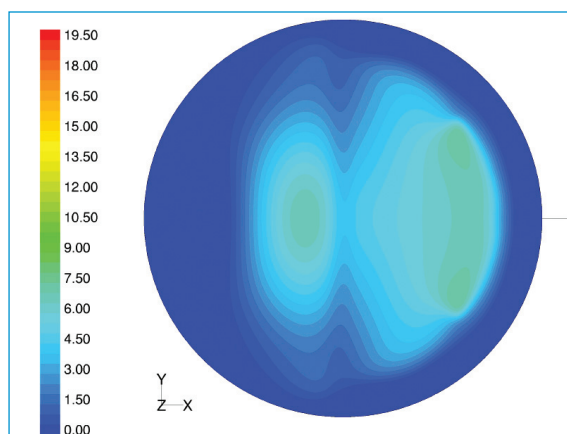

Model 758 Enhanced Vapor Horn with radial inlet.

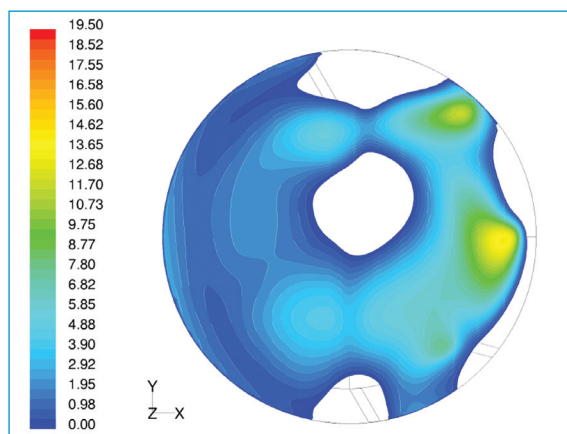

Model 758 Enhanced Vapor Horn with tangential inlet.

Uplift Resistant Designs

Koch-Glitsch designs for heavy-duty uplift resistance reduce the risk of equipment damage.

The industry standard practice for the mechanical design of trays and other tower internals is limited to a normal operating load and a maintenance load. This standard design criteria does not consider upset or uplift design conditions. For towers prone to upsets, it is recommended that the design of the tower internals be upgraded for a heavy-duty uplift resistance. The additional expense for the upgraded design often pays for itself by reducing the risk of equipment damage that can lead to significant losses in production, poor product quality, and/or an unplanned unit shutdown.

Because upsets are generally unsteady conditions, it is extremely difficult to predict the force generated by a specific column upset. Two levels of uplift protection are generally offered depending on the amount of protection desired: 1 or 2 psi [52 or 104 mmHg] net uplift. For design calculations, Koch-Glitsch uses the 1 or 2 psi as the total upward force.

A variety of different hardware configurations is available to provide a given level of uplift protection. For packed systems, a high-strength hold-down grid is typically used when uplift protection is needed. A common design for short beds of grid and structured packing uses rods through the packed bed, so the packed bed becomes a single structural element. This design often eliminates the need for larger support structures that can interfere with the vapor and liquid flow and increase the possibility of fouling or coking.

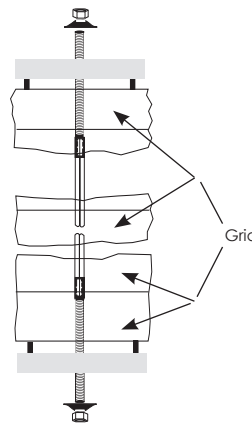

Through rod.

Trays can be designed to resist upsets by the use of reduced bolt/clamp spacing and heavy duty hardware, reduced panels widths and increased deck thickness. When more severe upsets are anticipated, shear clips are added to stabilize the tray panel's integral stiffeners. For extreme conditions, explosion doors may be used to protect the trays, especially where frequent upsets are anticipated.

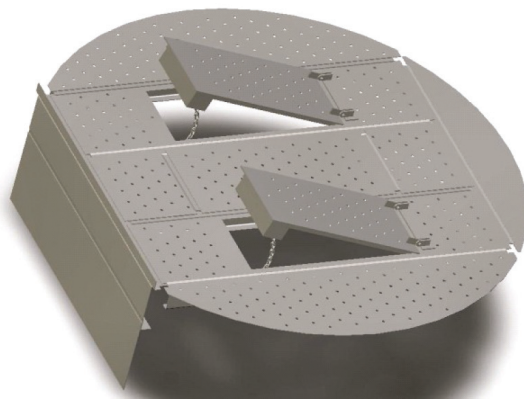

Explosion doors can provide protection to trays during an upset.

Typical Applications

- Steam strippers or steam stripping sections of refinery fractionators
- Wash sections of crude atmospheric, crude vacuum, lube vacuum and coker main fractionator towers



Hold down grid with through rod for a structured packing or grid bed.



Special uplift protection design for a parting box of a liquid distributor.

KFBE Fluidized Bed Structured Packing

Designed to meet the demanding needs of gas-solid fluidized bed systems.

KFBE fluidized bed structured packing was developed by Koch-Glitsch specifically to meet the demanding needs of gas-solid fluidized bed systems. Robust and efficient, KFBE packing distributes gas and solid flows evenly, breaks up large gas bubbles and enhances gas-solid contact without restricting flow or creating areas of solids stagnation. The result is higher capacity, increased efficiency and a stable fluidization profile maintained over a wide range of operating conditions.

KFBE packing has been successfully applied in more than 65 FCC spent catalyst stripper applications. Although disc and donut or shed-deck type trays have been traditionally used, these designs can easily block 50% of the available cross-sectional area, thereby restricting catalyst circulation and overall unit performance.

With more refiners facing catalyst circulation and stripping efficiency limitations, there is an increasing need for higher capacity and more efficient stripper internals. KFBE packing has met this challenge by allowing full use of the vessel cross-sectional area, eliminating catalyst stagnation and fully activating the available stripper volume. Capacity, residence time and stripping efficiency are simultaneously increased with a corresponding improvement in overall unit performance and operating flexibility.

Stripping steam is also reduced resulting in less steam traffic to the FCC main fractionator and a reduction in sour water discharge.

KFBE packing provides operating flexibility and allows system optimization to meet plant production requirements for both retrofit and new installations. KFBE packing encourages free catalyst flow and is constructed to meet life cycle requirements.

Advantages

- Increased hydrocarbon recovery
- Increased hydraulic stability
- Increased residence time
- Reduced regenerator oxygen demand

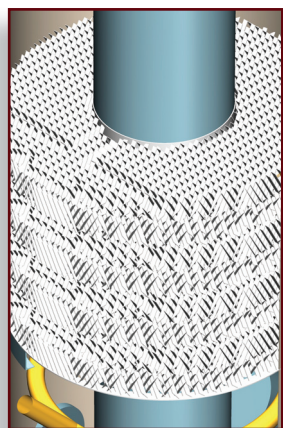
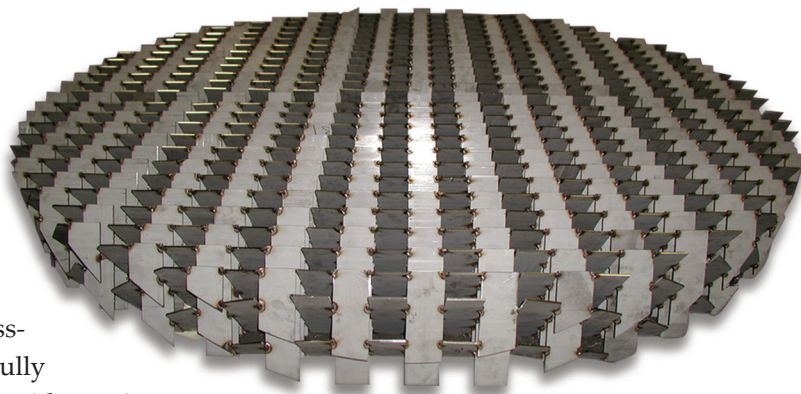

KFBE packing.

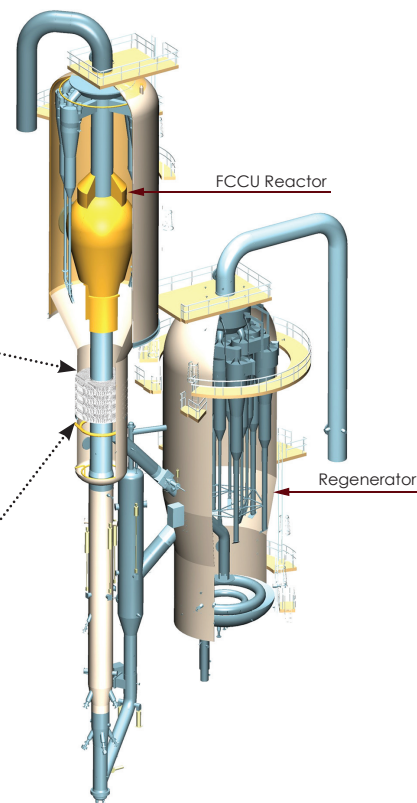

FLEXICHEVRON® Mist Eliminators

Ideal for applications where plugging of wire mesh mist eliminators is a risk.

FLEXICHEVRON® mist eliminators are characterized by smooth blade profiles and wide blade spacing that provide additional fouling resistance. Koch-Glitsch offers an extensive line of FLEXICHEVRON mist eliminators to meet the demanding requirements of applications where undissolved solids can be present or droplets can be sticky or viscous.

High Capacity and Low Pressure Drop

FLEXICHEVRON mist eliminators have vapor flow paths that are more open than other types of mist eliminators. As a result, they provide higher capacity and lower pressure drop than other mist eliminators. FLEXICHEVRON mist eliminators are a good selection for use in refinery vacuum towers, scrubbers and evaporators.

Fouling Resistance

Certain blade profiles of FLEXICHEVRON mist eliminators are designed to drain freely and minimize surfaces for solids to collect. The drawing of the two-pass FLEXICHEVRON mist eliminator illustrates these characteristics.

Although vane-type mist eliminators are resistant to fouling and plugging, they commonly use an irrigation system to keep the blades wetted. Proper wetting of the blades reduces the build-up of solids.

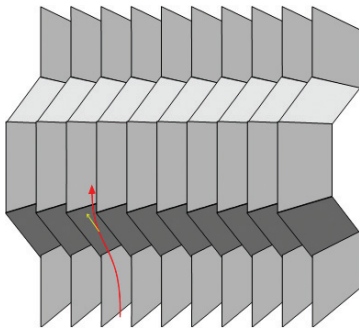

Two-pass FLEXICHEVRON® mist eliminator profile.

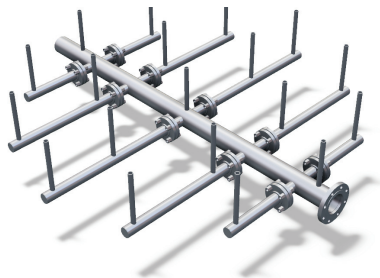

Spray distributor for FLEXICHEVRON® mist eliminator.

Resistance to Upsets

FLEXICHEVRON mist eliminators are fabricated with an integral brace that provides a rigid welded framework and maintains the pitch of the blades. An alternate construction using rods and tube spacers allows for open ends to conduct manual washing. FLEXICHEVRON mist eliminators are supplied with clamps for added stability when installing from below the support ring.

Materials of Construction

- Carbon steel
- Stainless steels
- Duplex stainless steels
- Nickel alloys
- FRP
- Thermoplastics

Applications

- Applications where plugging of wire mesh and/or fiber mist eliminators is a risk
- Applications where droplets will be sticky or viscous and will plug classic knitted wire mesh mist eliminators
- Air pollution control scrubbers where dissolved or undissolved solids can be present
- High vacuum applications, such as evaporators and vacuum crude units, where minimum pressure drop is critical
- Quench tower
- Flue gas desulfurization
- Caustic evaporators
- Vertical or horizontal flow

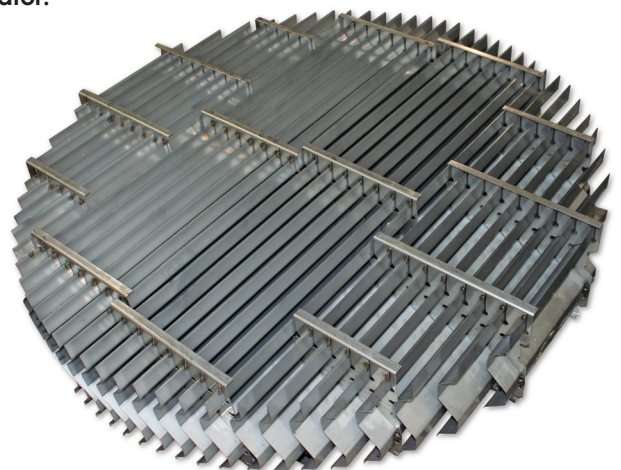

FLEXICHEVRON® style VIII mist eliminator in metal.

Liquid-liquid Coalescers

Custom designs for fouling service.

Koch-Glitsch offers a wide variety of liquid-liquid settling media to meet the demanding requirements of severe applications. Liquid-liquid settling media are characterized by wide plate spacing that provides additional fouling resistance.

High capacity and low pressure drop

Liquid-liquid settling media have open flow paths for liquid to pass through. These flow paths, or chambers, produce laminar flow and minimize eddy currents. The chambers also provide multiple interfaces within the separator allowing the dispersed phase droplets to reach a liquid surface and coalesce.

As a result, high capacity and high efficiency can be achieved with minimal pressure drop. Higher capacity allows for more compact designs for new separator drums or can help debottleneck existing drums.

Fouling Resistance

The open flow paths of the liquid-liquid settling media are the preferred design features where the potential for solids or tarry liquids exists. The settling media is typically provided in framed plate bundles. These characteristics are visible in the picture.

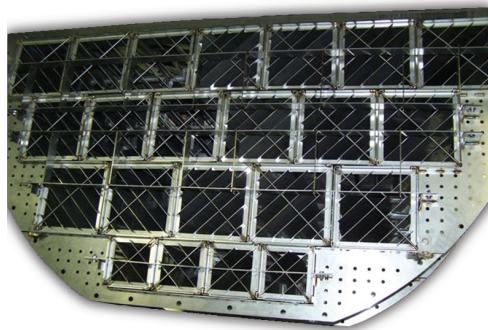
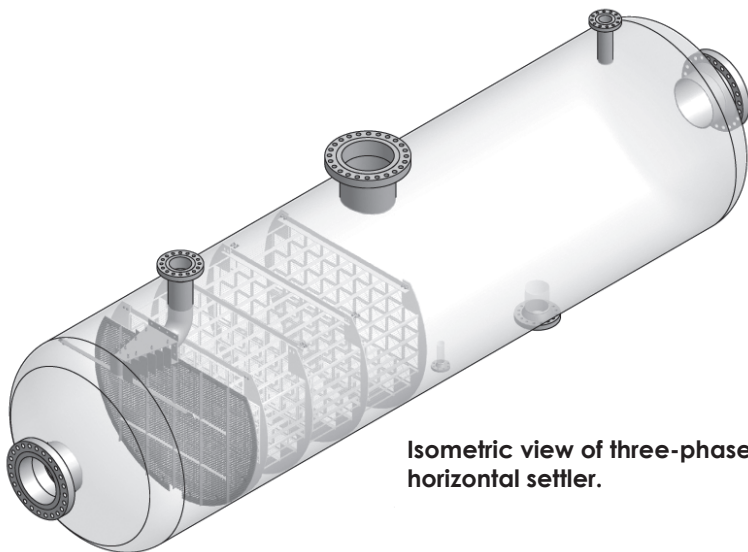

Plate pack media.

Resistance to upsets

The liquid-liquid settling media is fabricated with a rigid welded framework to maintain the pitch and angle of the plates. The framed sections are designed to pass through manways and are assembled within special support systems.



Isometric view of three-phase horizontal settler.

Materials of Construction

- Carbon steel
- Stainless steels
- Duplex stainless steels
- Nickel alloys

Construction Options

- Custom box sizes for optimal layout
- Custom lengths
- 14 ga [2.0 mm] to 22 ga [0.7 mm] construction

Applications

- Applications where plugging of wire mesh and/or fiber coalescers is a risk
- Applications that have a high concentration of dispersed phase
- Fractionator overhead reflux drums
- Wastewater treatment applications
- Quench tower water separator
- Upstream oil and gas processing

Applications

Delayed and Fluid Coker Units

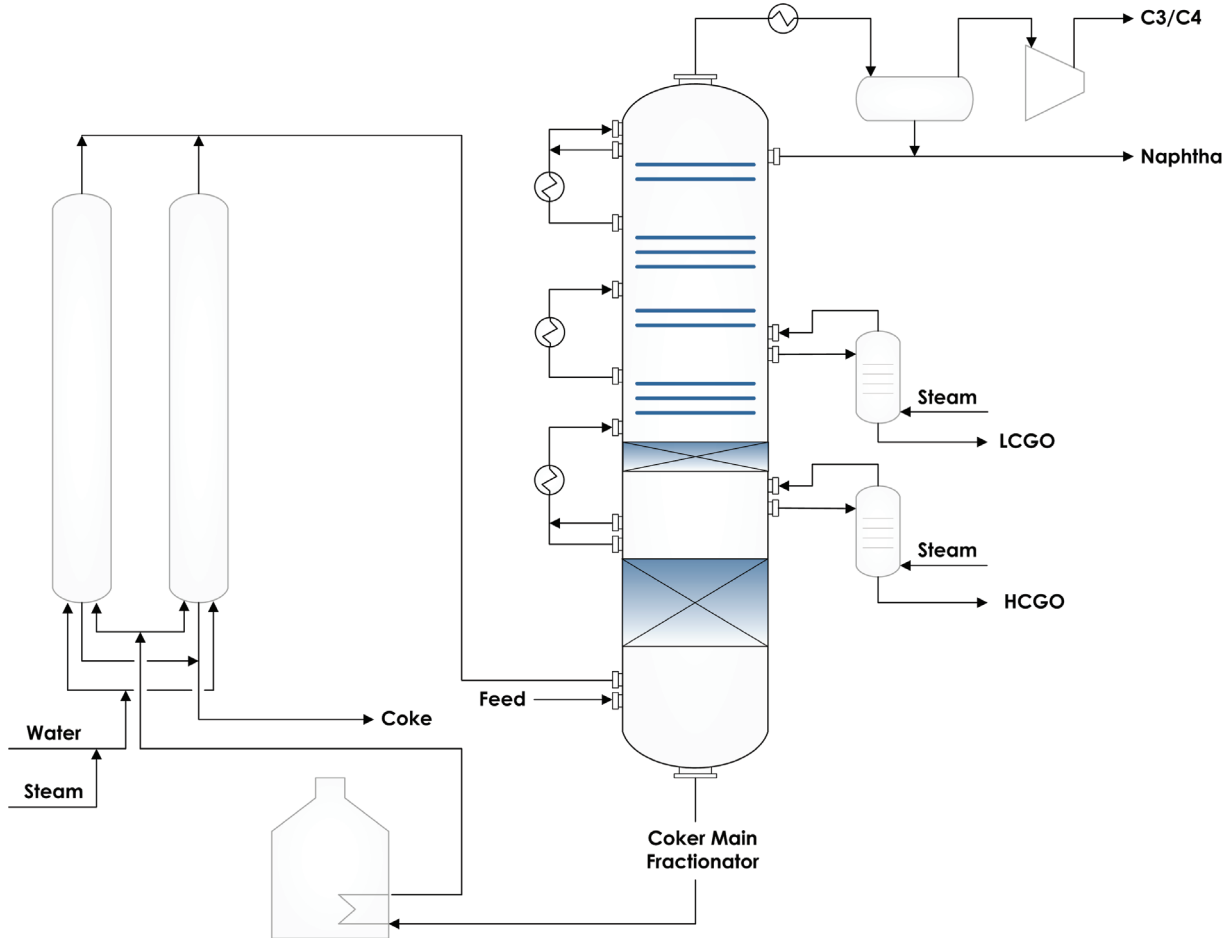

Coker Main Fractionator

The Coker Main Fractionator is one of the most severe distillation services in a refinery. The heavy material processed in the high temperature environment is very prone to coking. In addition, the drum switches, resulting in drastic load changes to the fractionator, increase the likelihood of damage to the tower internals. The top section of the Fractionator is also prone to the corrosion and salt deposition that are observed in other refinery fractionators.

Most Coker Main Fractionators are initially designed with conventional valve or sieve trays. However, there are many cases where an expansion in capacity requires the use of either high capacity trays or structured/grid packings. PROVALVE® trays or SUPERFRAC® trays can provide improved capacity and fouling resistance. The significant pressure drop savings obtained with FLEXIPAC® structured packing and FLEXIGRID® severe service grid packing can also provide an increase in gas oil yield by allowing a lower coke drum pressure.

FLEXIGRID packing is more frequently used in the wash section for towers that require a higher quality heavy coker gas oil (HCGO) and operate at very high vapor velocities. FLEXIGRID packing provides better efficiency than spray chambers, thus allowing better de-entrainment of coke fines and improved fractionation of the tail of the HCGO product. FLEXIGRID style 2 packing is recommended due to its superior fouling resistance and higher capacity.

The HCGO pumparound is usually the capacity bottleneck of the Coker Fractionator. The potential for fouling in this section remains very high. When high capacity trays can no longer provide the desired capacity, FLEXIGRID style 2 packing can be installed in the HCGO pumparound section.

Crude Distillation Unit

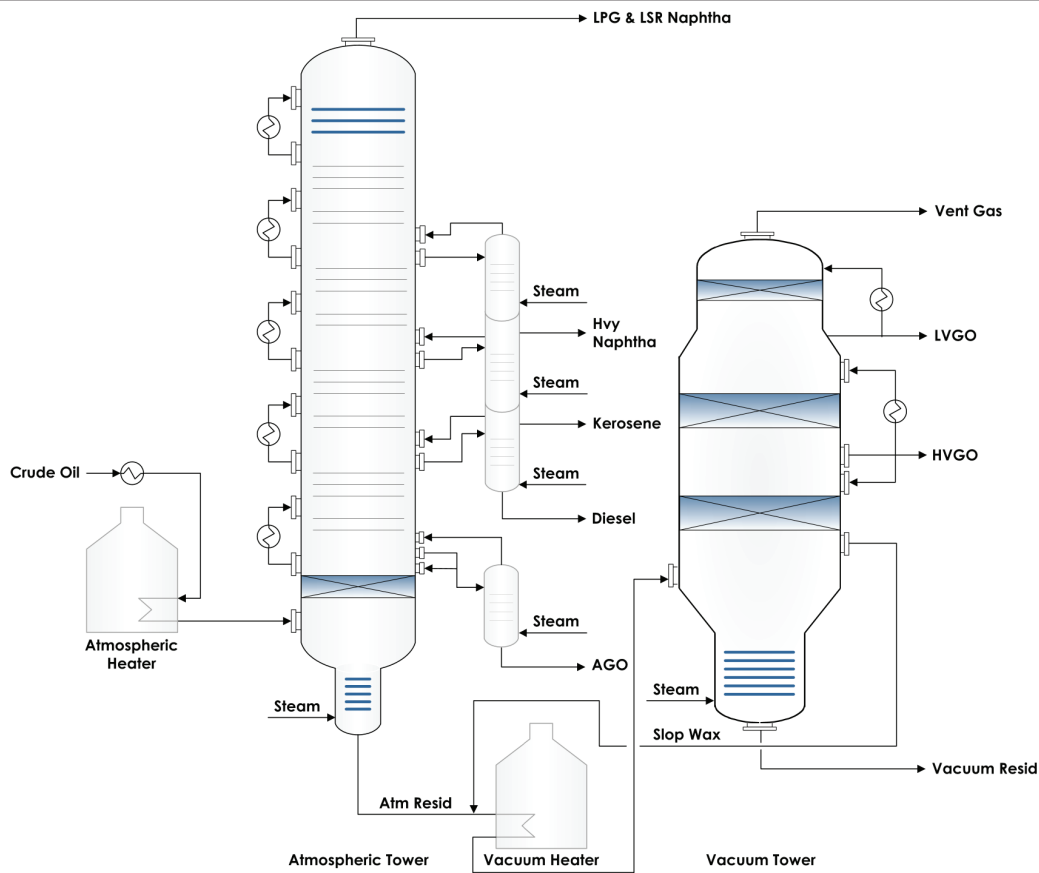

Atmospheric and Vacuum Crude Towers

Corrosion and fouling due to salt deposition in the top section of the crude tower and other refinery fractionators is common due to the low overhead operating temperatures. Careful material selection for the uppermost tower internals is critical for corrosion protection. For most crude units, trays with fouling-resistant fixed valve units, such as PROVALVE® units, are recommended for the greatest protection from fouling and corrosion products. Packing can also be used when necessary by using proper equipment designs. A heavier, more corrosion-resistant packing, such as PROFLUX® or FLEXIGRID® severe service grid packing, is generally recommended for these cases.

PROFLUX severe service grid packing is the preferred packing in crude unit wash zones due to its resistance to fouling, heavy-duty construction and good de-entrainment capabilities. Through rods and/or heavy-duty holddown grids are often recommended to increase the protection from damage due to possible upset.

Model 943 spray nozzle distributors are typically recommended for distribution of the wash oil to the top of the bed. The larger spray nozzle orifices, in conjunction with the significantly higher distributor velocities, make the spray distributor a more reliable distributor than other distributor types at the low wash oil rates. For very light crudes, Vacuum Columns with a low flash zone temperature and/or Lube Vacuum Columns with moderate risk for fouling and coke formation, a Model 156 trough type liquid distributor may also be considered.

For optimum vapor distribution and feed de-entrainment, the Model 758 Enhanced Vapor Horn is the preferred flash zone equipment.

The stripping sections are prone to fouling and have a high potential for upsets due to the presence of steam. High performance fixed valve trays with heavy duty uplift designs are generally recommended for the stripping sections. Koch-Glitsch offers a full line of fouling-resistant fixed valve trays, such as PROVALVE and SUPERFLUX® trays.

Fluid Catalytic Cracking Unit

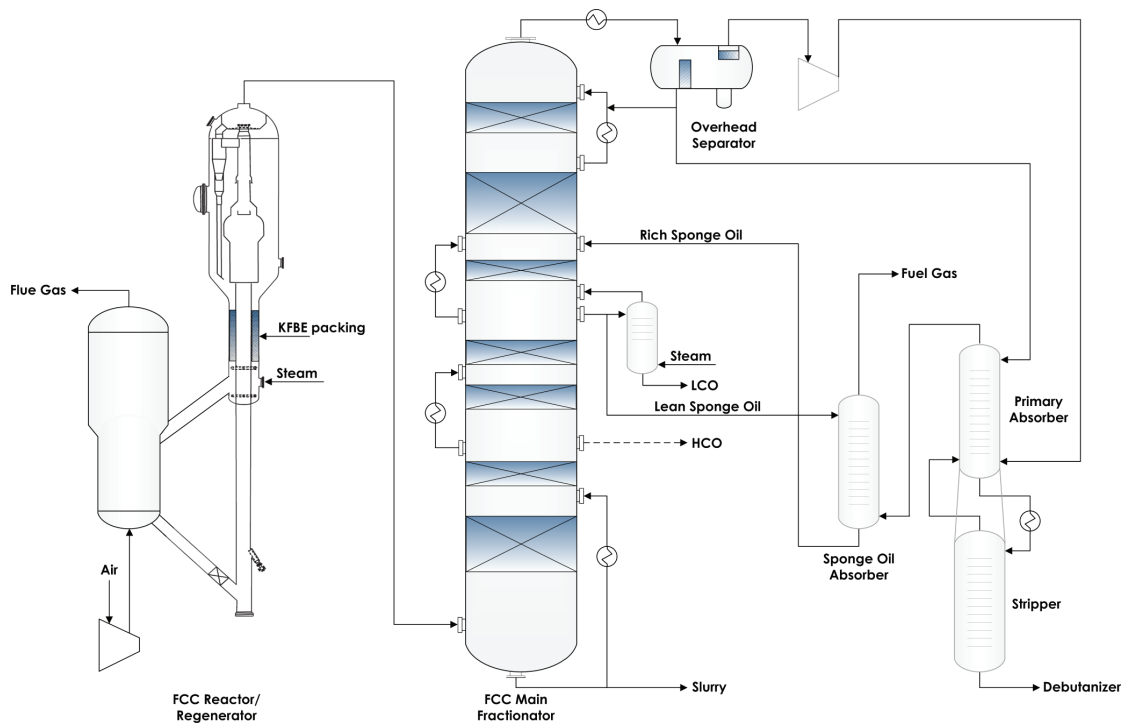

FCC Reactor/Regenerator

KFBE packing maximizes stripper efficiency and optimizes residence time and catalyst circulation in FCC Spent Catalyst Strippers. Regenerator temperature and after-burn are reduced. Overall unit performance and operating flexibility are improved.

FCC Main Fractionator

Structured packing in the FCC Main Fractionator Unit offers increased capacity, lower pressure drop and improved efficiency compared to trays. The lower pressure drop can offer a number of valuable benefits: increased gasoline yields; reduced load on wet gas compressor, regenerator and/or air blower; reduced coke formation on catalyst; and improved octane number of gasoline.

Severe conditions in the lower sections – particularly the slurry pumparound zone – require special equipment designs. The high temperature in the slurry pumparound promotes coke formation. In addition, catalyst fines from the reactor are introduced into the Main Fractionator with the vapor feed. The catalyst fines are often found as high up as the HCO pumparound and can cause erosion problems and plugging of liquid distributor orifices. Koch-Glitsch pioneered the use of grid packing in the slurry pumparound zone in FCC units. The superior fouling resistance and high capacity of the FLEXIGRID® style 2 packing make it the preferred packing selection. Koch-Glitsch offers special liquid and vapor distributor designs (Models 985 and 798), which have been developed and enhanced specifically for this application.

In addition, refiners that run unhydrotreated feeds, purchased feeds from a barge or tanker, or resid may also experience corrosion and fouling problems in the uppermost tower internals similar to problems seen in the top section of other refinery fractionators.

FCC Main Fractionator Overhead Separator

These separator drums can become a bottleneck when the fractionation towers are fitted with higher capacity internals. Higher throughput rates in the revamped column can increase separation demands on the overhead separator. The use of liquid-liquid settling media enhances separation of water in the reflux stream to help prevent corrosion of the column internals and reduce vapor traffic in the fractionation column.

Ethylene Quench Unit

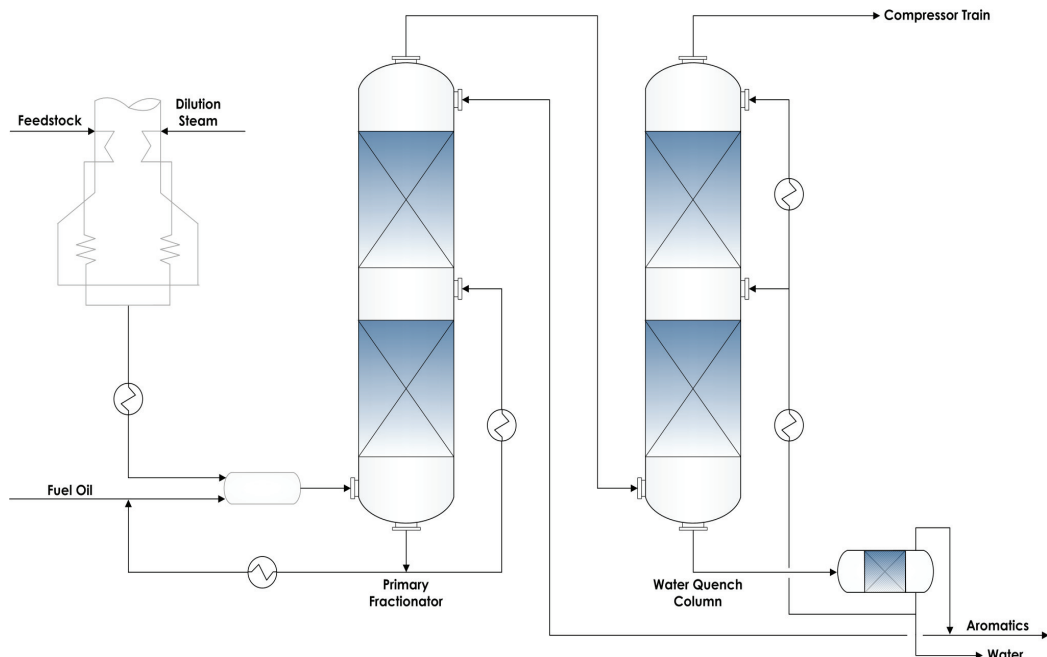

In Ethylene (Olefins) plants, significant fouling potential exists in the Quench columns that cool the hot process gas from the cracking furnaces. Coke fines from the cracker are entrained with the vapor to the first column in the Quench Unit. This first column will be an Oil Quench (Primary Fractionator) when cracking naphtha liquids or a Water Quench column for ethane or propane feedstocks.

In older Ethylene Units, the column section above the cracked gas inlet will often contain open-type trays. The efficiency of this section can be improved by the use of PROFLUX[®] and FLEXIPAC[®] S packings. At the bottom of the column (nearest to the cracked gas inlet), PROFLUX packing can be used to maximize column capacity and minimize fouling from the entrained coke solids. As the vapor cools and the worst fouling is eliminated, the packing type can be changed to FLEXIPAC S packing for high efficiency while retaining effective fouling resistance. As a result of the additional packing efficiency, the liquid outlet temperature from the column can be increased, resulting in greater heat recovery from the Ethylene Quench Unit.

In the upper section of these columns, where fouling is less of a concern, high performance INTALOX[®] ULTRA random packing or FLEXIPAC[®] HC[®] structured packing is often used to provide greater efficiency for additional fractionation or increased cooling of the process gas. Heavy hydrocarbons and water entrained in the vapor can cause foaming and fouling in downstream equipment. A FLEXICHEVRON[®] mist eliminator can help improve the purity of the overhead vapor and help reduce water entrainment in the hydrocarbons going to downstream knockout drums.

Liquid at the bottom of the quench column is usually contaminated with coke fines washed from the process vapor. The fouling resistant Model 943 spray nozzle distributor or Model 985 trough distributor with V-notch weirs are often used to recirculate the liquid in the bottom pumparound. Oily water in the bottom section can load wastewater treatment facilities. Liquid-liquid settling media can help maximize oil recovery, which helps minimize the oil concentration in wastewater and unload downstream water treatment facilities.

A series of knockout drums removes liquid hydrocarbons from gases before compression. Using DEMISTER-PLUS mist eliminators can maximize liquids recovery, increase capacity, and help protect compressors from damage caused by severe liquid entrainment. A YORK-EVENFLOW vane inlet device used at the inlet nozzle gradually reduces high inlet gas momentum, which helps reduce droplet shatter. The inlet device also reduces the required vessel height that is critical to achieve uniform gas velocities above the inlet in compact separators.

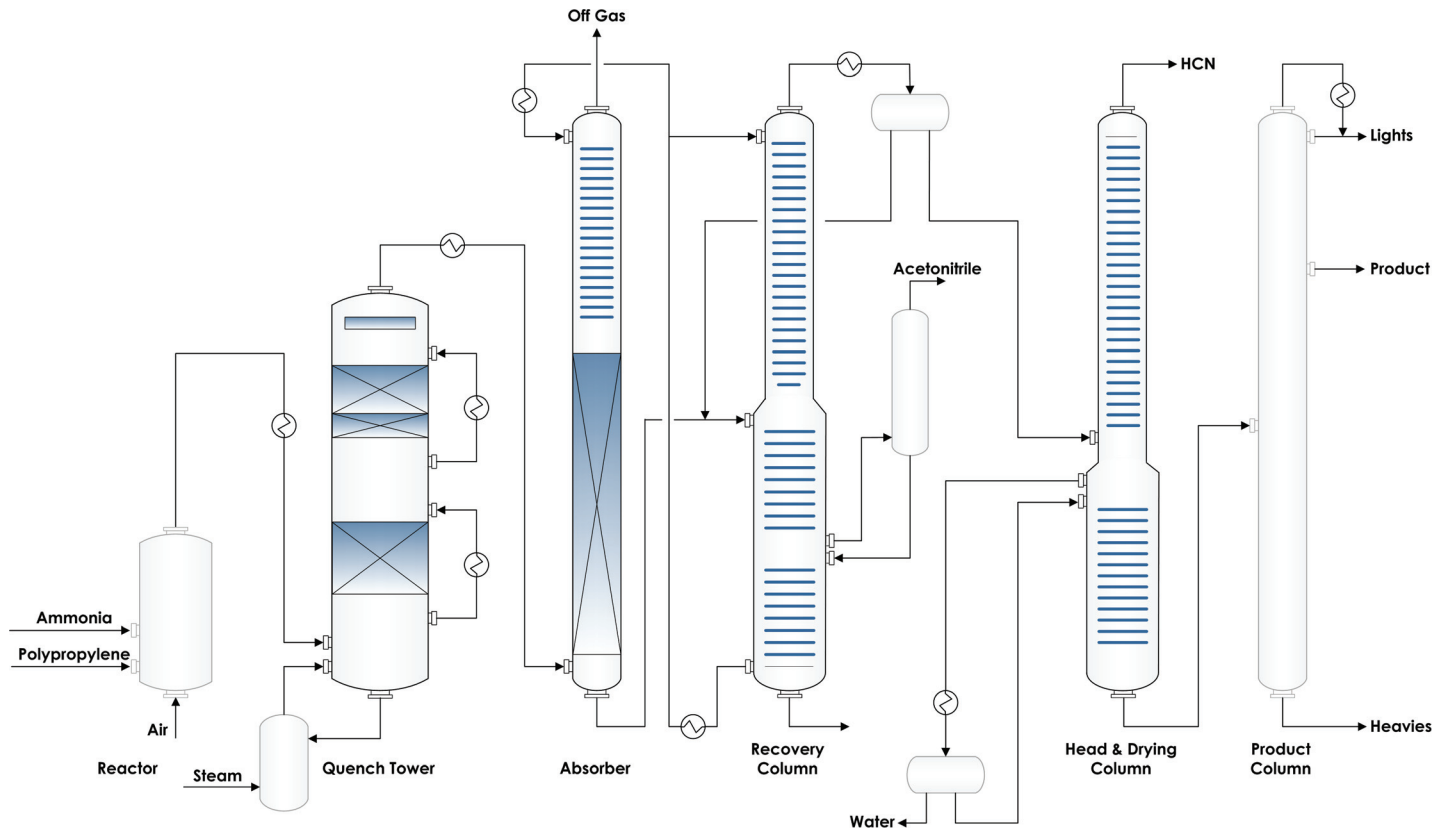

Polymerization and coking can cause major operational problems in an acrylonitrile plant, leading to premature shutdowns and lost production. Koch-Glitsch can provide a variety of internals to reduce or eliminate these problems.

Quench Tower

Liquid entrainment from the quench section (lower) into the neutralization section (upper) can cause polymerization. In the lower bed, combining a well-designed Model 758 Enhanced Vapor Horn with PROFLUX[®] severe service grid can provide maximum de-entrainment performance. Liquid entrainment from the neutralization section can cause fouling in the recovery column. A combination bed of PROFLUX severe service grid and FLEXIPAC[®] S structured packing is recommended. A FLEXICHEVRON[®] mist eliminator at the top of the tower will provide final protection against liquid carryover. A fouling-resistant Model 985 liquid distributor is also recommended.

Absorber

The use of FLEXIPAC S structured packing will reduce the pressure drop in the column allowing a lower vapor feed inlet pressure and temperature. The lower temperature reduces the potential for polymerization and fouling. PROVALVE[®] fixed valve trays are preferred for the upper section because flushing action of the vapor eliminates stagnant liquid zones on the trays that otherwise would be subject to polymerization.

Recovery Column

The recovery column is also subject to polymerization and severe fouling. Using a combination of SUPERFRAC[®] and/or SUPERFLUX[®] trays with PROVALVE units will result in higher capacity and longer run length compared to conventional valve trays.

Head and Drying Column

HCN in the overhead causes so-called coffee ground type polymerization, while AN in the bottoms leads to a coating type polymer. SUPERFLUX or PROVALVE trays minimize stagnant liquid pools leading to longer run length and less down time.

Koch-Glitsch Corporate Offices

Worldwide Headquarters

Koch-Glitsch, LP

4111 East 37th Street North

Wichita, KS 67220 - United States

tel: (316) 828-5110

fax: (316) 828-7985

Europe

Koch-Glitsch Italia S.r.l.

Via Torri Bianche, 3A

20871 Vimercate - MB - Italy

tel: +39-039-6386010

fax: +39-039-6386011

Asia

Koch Chemical Technology Group Singapore Pte. Ltd.

260 Orchard Road, #11-01/09
The Heeren

Singapore 238855

tel: +65-6831-6500

fax: +65-6835-2031

Koch-Glitsch (a division of Koch Chemical Technology Group India Pvt. Ltd.)

10th Floor, Corporate Park II
Sion-Trombay Road

Chembur, Mumbai 400 071 - India

tel: +91-22-6771-7171

fax: +91-22-6771-7161

For a complete list of our offices and facilities, visit us on the Web at www.koch-glitsch.com.



Emergency Numbers

United States/Latin America: 1-888-KOCH-911 (mass transfer), 1-316-207-7935 (mist elimination), or your local Koch-Glitsch office.

Canada: 1-905-852-3381 (Uxbridge, Ontario).

Europe/Middle East/Africa: +39-06-928-911 (Italy), +44-1782-744561 (UK), or your local Koch-Glitsch office.

Asia : +65-6831-6500 (Singapore) or your local Koch-Glitsch office.

Trademarks

The following registered trademarks are owned by Koch-Glitsch, LP in the United States and may be registered in other jurisdictions: FLEXICHEVRON® mist eliminator, FLEXIGRID® severe service grid packing, FLEXILOCK® tray construction, FLEXIPAC® structured packing, FLEXIPAC® HC® structured packing, FLEXIPAC® S structured packing, GLITSCH GRID® severe service grid packing, INTALOX® ULTRA random packing, KOCH-GLITSCH, "K" KOCH-GLITSCH (logo), PROFLUX® severe service grid, PROVALVE® tray, SUPERFLUX® tray, and SUPERFRAC® tray. The following trademarks are owned by Koch-Glitsch, LP in the United States and may be registered in other jurisdictions: DEMISTER-PLUS mist eliminator, KFBE fluidized bed structured packing, PURGE downcomer, YORK-EVENFLOW vane inlet device and YOU CAN RELY ON US. All other trademarks, service marks, or registered trademarks that appear in this document are the trademarks or service marks of their respective owners.

For related trademark information, visit <http://www.koch-glitsch.com/trademarks>.

Patents

The following technologies are protected by one or more patents in the USA; other foreign patents may be relevant: FLEXILOCK® tray construction (US6592106), FLEXIPAC® HC® structured packing (US5632934, US6478290), INTALOX® ULTRA random packing (US7722945), KFBE fluidized bed structured packing (US6224833), Model 758 Enhanced Vapor Horn (US6889961, US5605654, US5632933, US66889962, US7104529), PROFLUX® severe service grid (US8298412), PROVALVE® tray (US5762834), SUPERFLUX® tray (US5895608), and SUPERFRAC® tray (US5762668, US5895608, US5632935).

Available exclusively from Koch-Glitsch, FLEXIPAC® HC® structured packing is protected by US Patent 5,632,934 and other patents worldwide assigned to Praxair Technology, Inc. Koch-Glitsch, LP is the exclusive worldwide licensee of Praxair Technology, Inc. for the manufacture and sale of this packing in all markets except for industrial gas separation.

Legal Notice

The information contained in this bulletin is believed to be accurate and reliable, but is not to be construed as implying any warranty or guarantee of performance.

 **KOCH-GLITSCH®**

Bulletin KGSP-2. Rev. 4-2015. Printed in USA.
© 2015. Koch-Glitsch, LP. All rights reserved.