

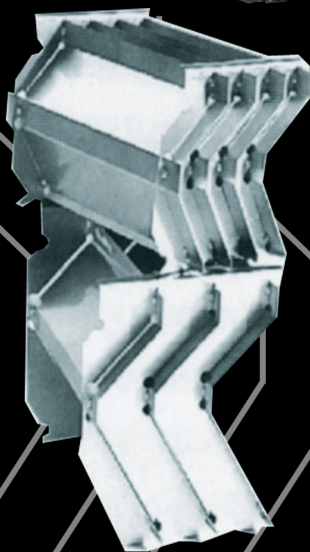

FLEXICHEVRON[®] ***Mist Eliminators***

FOR FLUE GAS DESULFURIZATION

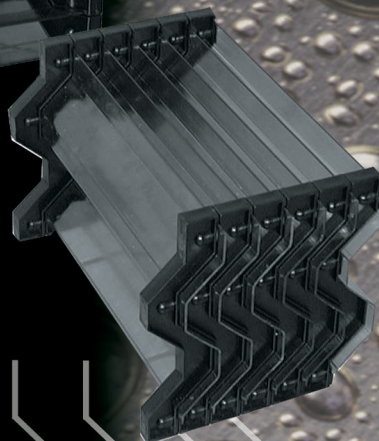
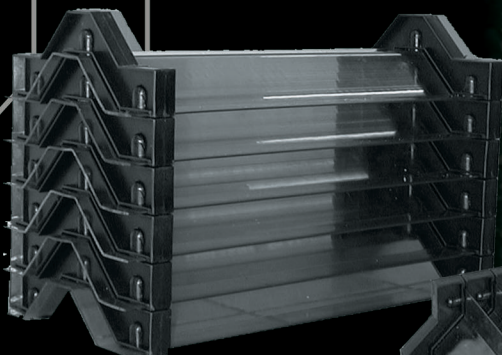
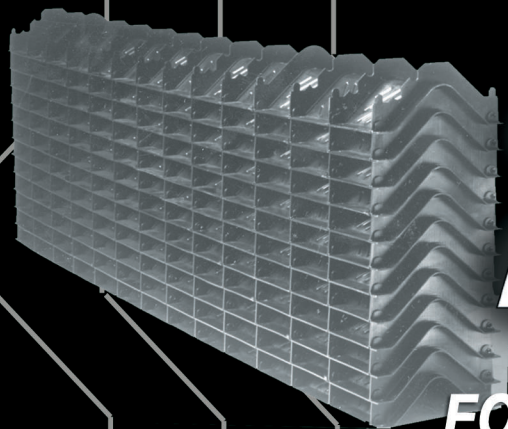

Style XIV

Style XII

KOCH-OTTO YORK[®]

SEPARATIONS TECHNOLOGY

OTTO YORK[™]

A Koch-Glitsch, LP business group

KOCH-GLITSCH ITALIA S.r.l.

KOCH FLEXICHEVRON® MIST ELIMINATORS IN UTILITY, REFINERY, AND OTHER INDUSTRIAL FGD SERVICES

FGD Application

Koch designs and manufactures a variety of products for flue gas desulfurization (FGD) applications. FGD applications are relevant to large electrical power producers, kiln flue gas for cement production, potline flue gas for aluminum or other metal foundries, flue gas from FCC units in refineries, or other power or process flue gasses which require SO₂ removal.

Processes vary depending on the amount of SO₂ involved, the solution being used to absorb the SO₂, and the particular equipment used in the absorption tower. The most common process is using lime/limestone slurry FGD systems. Chemistry for this particular process involve a lime or limestone slurry which consists of a solution of calcium compound solids in suspension as well as calcium salts (sulfites and sulfates) in solution. These dissolved compounds are generally not a significant problem unless the solution is saturated. In this case, as free Ca⁺⁺ ions and SO₂ (aq) continue to react, the resulting products are calcium sulfite and sulfate in varying proportions depending upon operating pH as well as other factors. The additional reaction of Ca⁺⁺ with CO₂ in the absorber form carbonate products, which will occur to a minor extent at low pH. At a pH above 8, significant carbonation occurs due to free calcium hydroxide in the absorber. This results in carbonate deposition on the internals, including the mist eliminators.

As the sulfite, sulfate, and carbonate compounds are formed in a supersaturated solution, precipitates are formed adding to the suspended solids level and scaling potential. Additives such as magnesium, sulfur, and dibasic acid (DBA) allow one to operate in an "inhibited oxidation" state, preventing precipitate deposition on equipment and mist eliminators.

It quickly becomes apparent that there are a number of variables affecting the equilibrium of reaction within the system. The main components for concern, in the mist eliminator zone, are calcium sulfite and calcium sulfate. The sulfite precipitates out as a soft, white material which is easily washed from any surface on which it settles. Calcium sulfate is a hard and difficult to remove compound. Once the sulfate precipitate has initially taken hold, whether it be in crevices, hidden zones, or rough area in general, further precipitation continues more rapidly.

FLEXICHEVRON® General Design

Some applications with lower SO₂ concentrations may warrant only one chevron level due to lower L/G ratios, or other unique tower geometries. However, for the majority of applications, the mist elimination zone is frequently made up of two stages of mist eliminators. This two stage design normally applies to either vertical flue gas flow or horizontal flue gas flow. The lower, or first stage mist eliminator is often referred to as the "roughing" or "bulk entrainment separator". It is typically characterized by a high capacity, open design with the intent on removing as much liquid as possible. Typically, this chevron level is irrigated intermittently from both the top and the bottom.

The second stage mist eliminator operates drier, is generally more efficient relative to the first stage, and is typically irrigated intermittently from the bottom only. At times, users may elect to have a top spray for the upper level mist eliminator, to periodically flush the system during low demand periods, or unit outages. Care must be taken to "balance" the performance of the two mist eliminator stages as each impact the performance of the other. Selecting a first stage ME that is too "open" will result in too much slurry getting to the second stage, and potentially plug and create a cleaning issue. Selecting a first stage that is too restrictive may also result in potential cleaning issues, due to the sheer volume of solids at the first stage level. Whether it be the first stage or the second stage mist eliminator, both levels offer a clean profile, free of any hooks or grooves that can accumulate solids buildup or impede washing. In essence, a "hydraulic hook" is created between chevron blades due to high and low pressure gradients. This hydraulic hook creates the same effect as a physical hook, i.e. a disengaging point to allow for liquid drainage, without the pluggage risk normally associated with using a real hook.

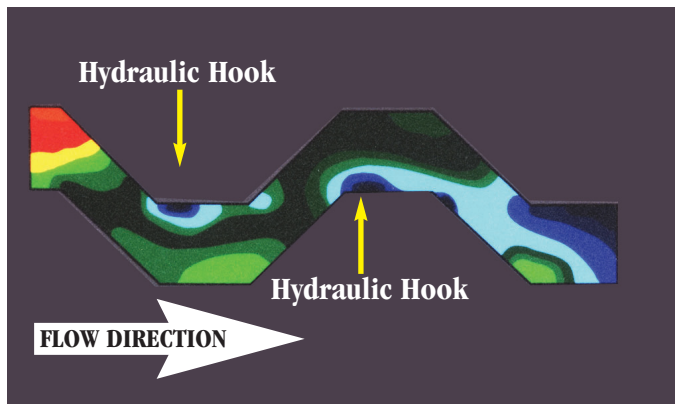

Pressure contours using CFD reflects low pressure areas resulting in liquid accumulation.

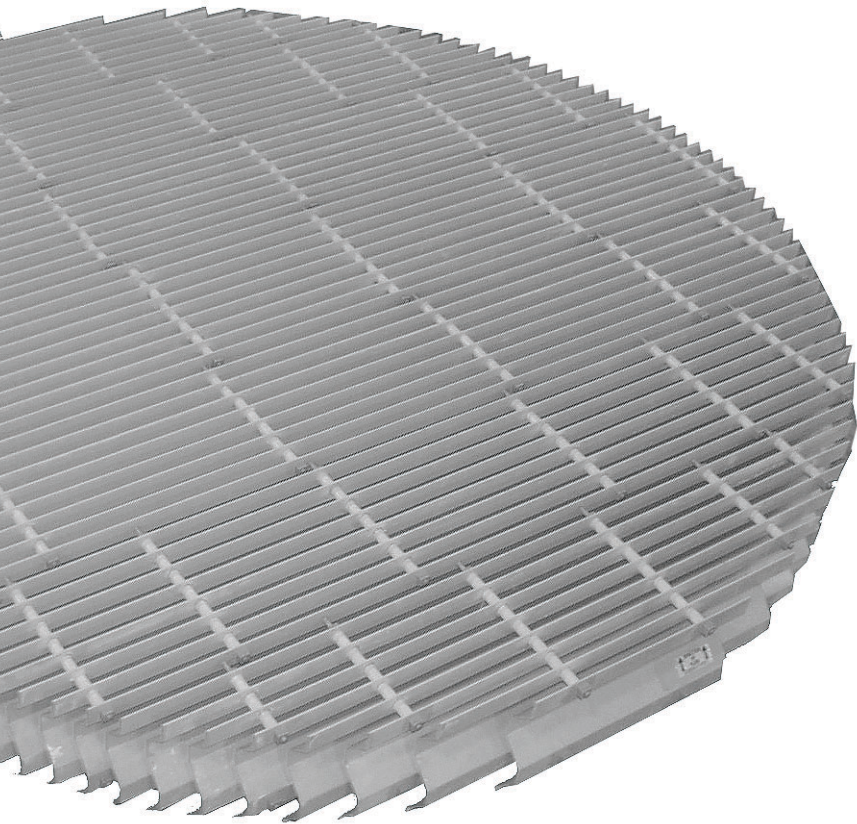

Koch-Otto York Design Pentagon

Customer requirements are such that Koch designs need to meet a multitude of requirements. For this reason, we have developed a "design pentagon" which ensures no detail will be overlooked in the FGD design

FLEXICHEVRON®	Polypropylene w/5% Glass	Polypropylene w/20% Glass	Polypropylene Steel	Polysulfone	FRP	Stainless
Style VIII	170	185	200	300	300	350+
Style XII/XIV	170	185	200	300	300	350+
Style XXVII	170	185	200	n/a	n/a	n/a
Style XXVIII	170	185	200	n/a	n/a	n/a

Temperature in degrees fahrenheit

Materials of construction vary widely depending on customer preferences, operating conditions, amount of chlorides in the flue gas, maintenance requirements, and ultimate product cost. For this reason, Koch offers a variety of materials with continuous operating temperatures, as listed above, when properly supported.

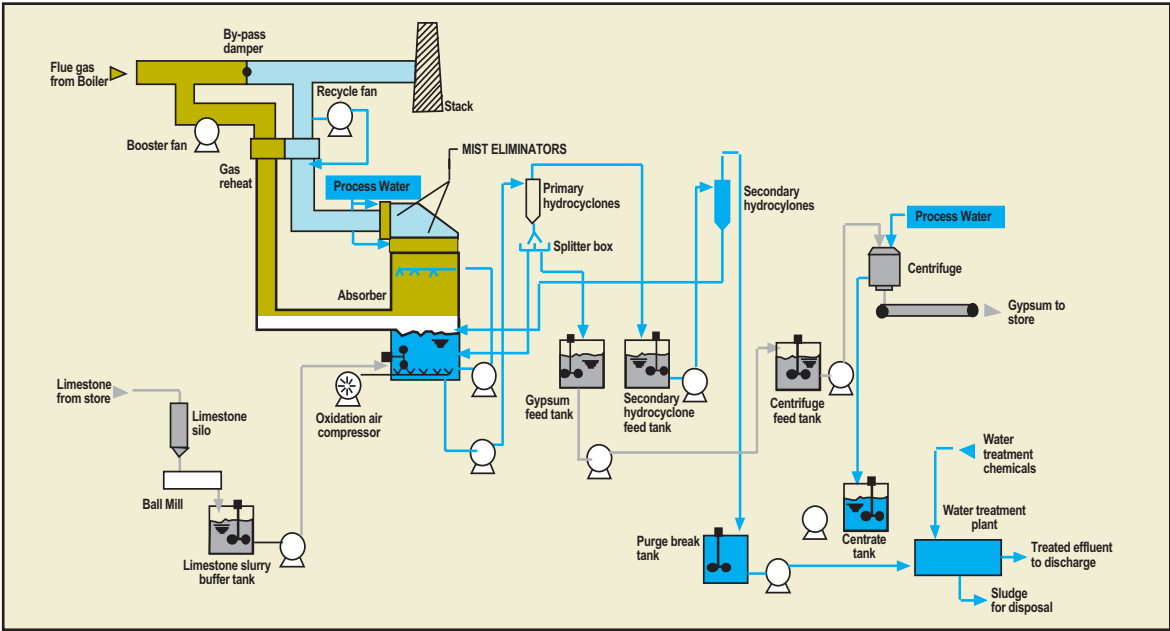

Limestone/Gypsum FGD plant - Process flow schematic

Spray Wash Design for FGD Systems

Koch has designed and supplied innumerable FLEXICHEVRON® mist eliminators for many applications for evaporators, process engineering, and air pollution control. Although a benefit of chevron type mist eliminators is their resistance to fouling and plugging, it is frequently necessary to include irrigation of the chevron. Otherwise, as material builds up on the chevron blades, local velocities increase due to less open area. This substantially increases pressure drop proportional to gas V^2 and may result in re-entrainment of collected droplets. Irrigation is required in the majority of FGD applications.

- Recommended slurry recycle in the wash water should not exceed 50%.
- A typical irrigation rate is $2.5 \text{ m}^3/\text{hr}/\text{m}^2$ of chevron cross section.
- Wash nozzles are typically mounted about 500mm from the near face of the chevron (vertical flow applications).
- Recommended wash water frequency should be a minimum of 60 seconds per hour.

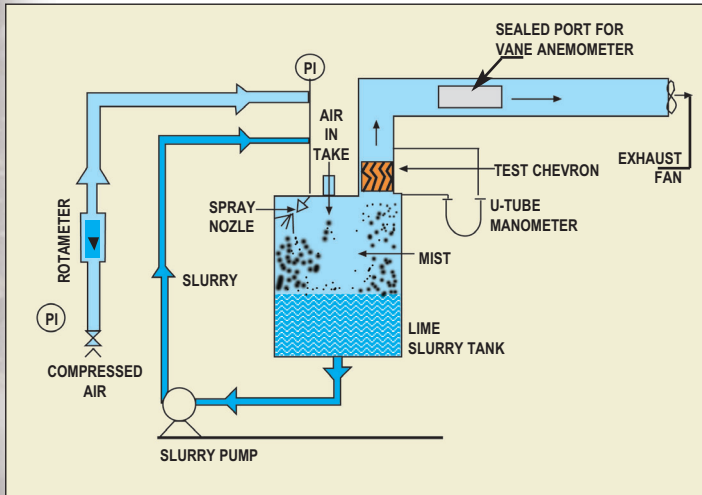

Test system for checking plugging resistance of FLEXICHEVRON®

Some mist eliminators are more resistant to fouling than others. Those with narrow blade spacings, or with more tortuous gas streams, are prone to more fouling as well as more difficult to accommodate wash water spray patterns. Hooks on a chevron in fouling service are ineffective as they quickly bridge over with solids. In comparative tests with other chevron products, FLEXICHEVRON® products were especially resistant to fouling and solids build up.

The essential requirements of effective chevron washing can be summarized as follows:

- The design of the chevron must be such that the wash liquor can reach all parts of the chevron where fouling may accumulate. Braces or other structural members must be designed to minimize interference with wash spray patterns.
- Spray nozzles should be full cone, $90^\circ - 120^\circ$ spray angles.
- Maintain wash water pressure at 2 bar minimum.
- Spray pattern coverage of the chevron should be 150% of chevron cross sectional area.

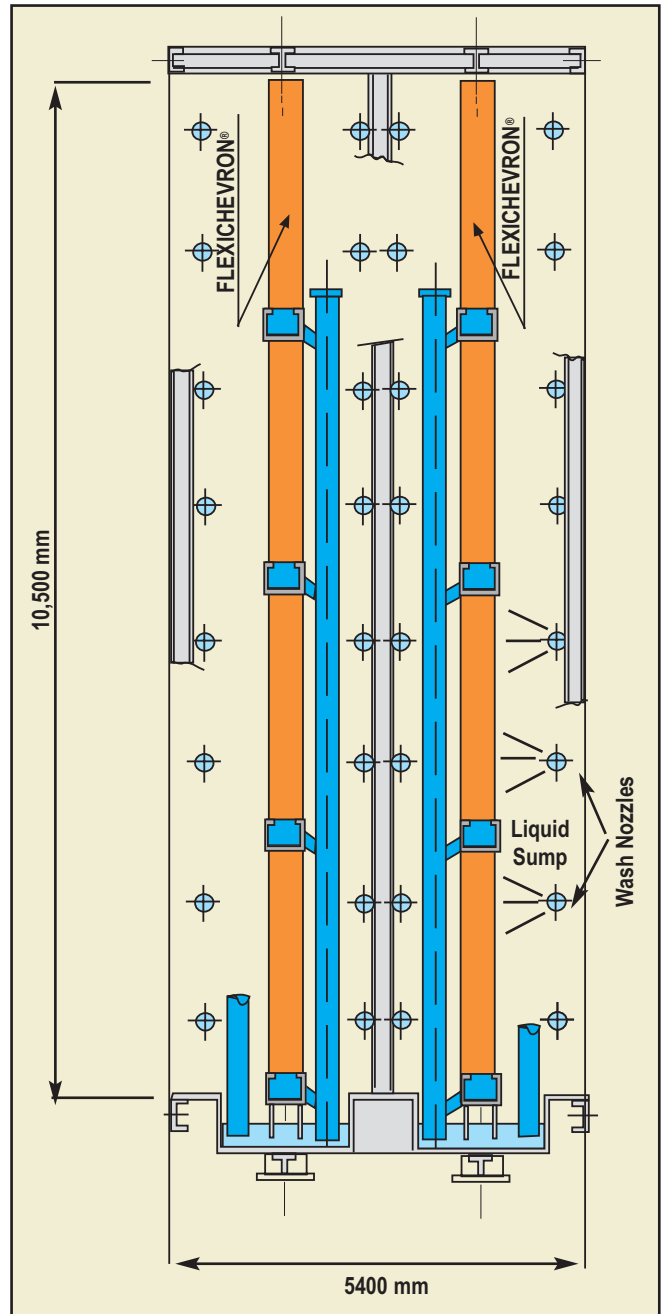

Side view of a two stage FLEXICHEVRON® and Washing System in a horizontal flow duct

Exact frequencies and wash water volumes can best be determined from plant experience, overall water balance required for the absorber, and total available wash water. The Koch applications engineer can tailor the design to specific customer requirements.

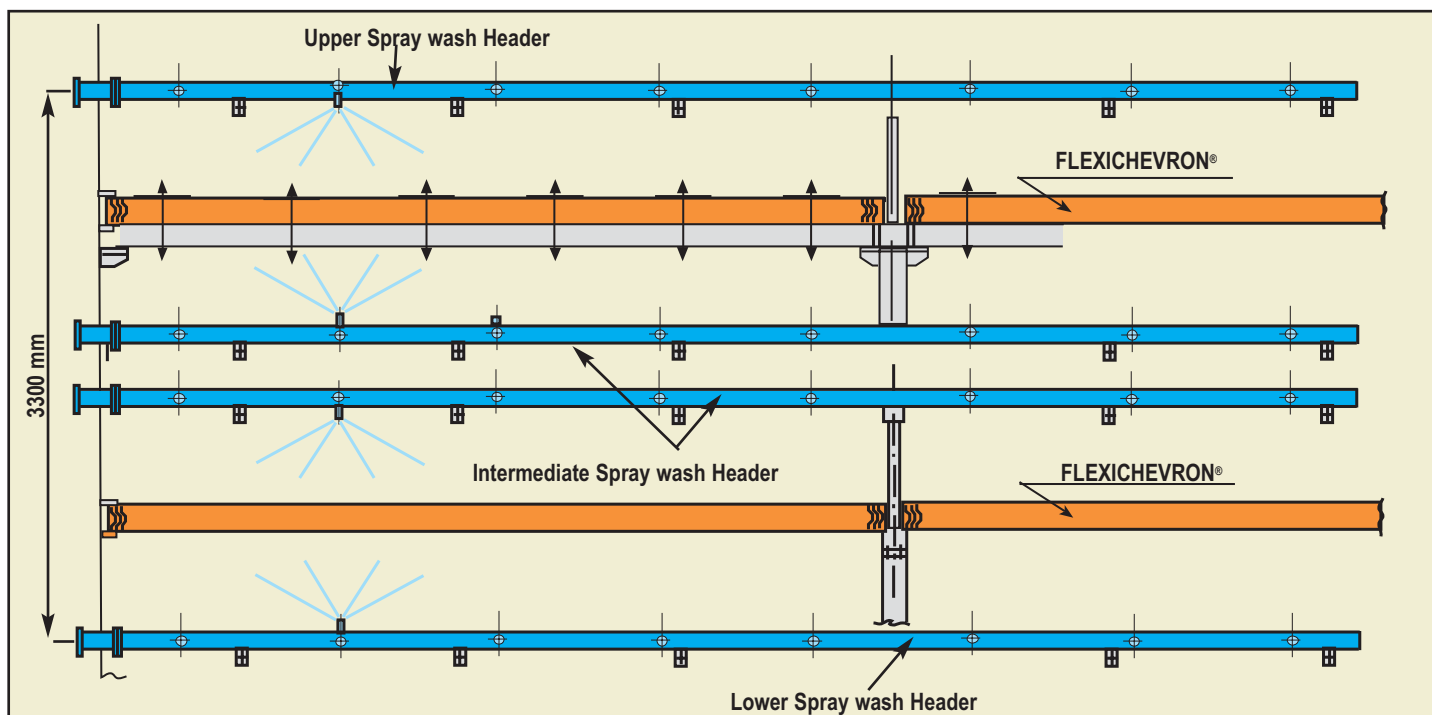

Side view of a two stage FLEXICHEVRON® and Washing System in a vertical tower.



Koch FLEXICHEVRON® Mist Eliminators for the FGD Industry

Koch offers many types of chevron mist eliminators to facilitate the numerous styles of absorbers and internal support arrangements.

FLEXICHEVRON® Style VIII Mist Eliminators

Multi purpose mist eliminators designed specifically for FGD absorbers where fouling, ease of cleaning, low pressure drop, and dependability are important. The Style VIII continues to occupy the majority of Koch FGD applications due to its rugged construction and low moisture carryover. The Style VIII can be used in either vertical or horizontal gas flow. The Style VIII can be either a single stage or multi stage application and is available in stainless steel, polypropylene, polysulfone, noryl, or fiberglass.



**FLEXICHEVRON®
Style VIII
Mist Eliminator**

FLEXICHEVRON® Style XII/XIV Mist Eliminators

Patented product primarily developed for vertical up flow, high velocity absorber application. The Style XII/XIV is a two stage arrangement with focus on mass removal for the first stage and efficiency for the second stage. Velocities of over 20ft/sec. are possible with these mist eliminators. The Style XII/XIV is available in polypropylene, polysulfone, stainless steel and fiberglass

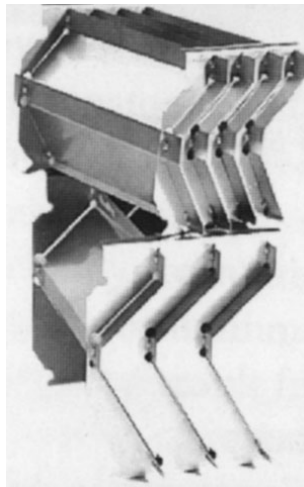

**FLEXICHEVRON®
Style XII/XIV
Mist Eliminators**

FLEXICHEVRON® Style XXVII Mist Eliminators

This mist eliminator combines excellent efficiency and strength at an economical price. The Style XXVII can be either a single stage or multi stage application and comes in standard vane spacing of 1.625", 1.125", or 0.875". The style XXVII is used as either original equipment or replacement equipment as retrofitting existing absorbers is a simple process using the existing mist eliminator support network. The mist eliminator is available only in polypropylene.

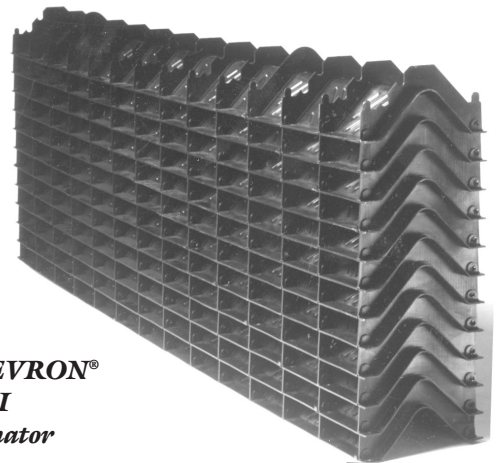

**FLEXICHEVRON®
Style XXVII
Mist Eliminator**

FLEXICHEVRON® Style XXVIII Mist Eliminators

The Style XXVIII is a tilted mist eliminator used as a bulk separation device in a multi stage mist eliminator arrangement. The Style XXVIII offers excellent capacity, low pressure drop, and liquid removal characteristics. Generally, the Style XXVIII is used in combination with the Style XXVII but can also be used with the Style VIII or Style XII. The mist eliminator is available only in polypropylene.

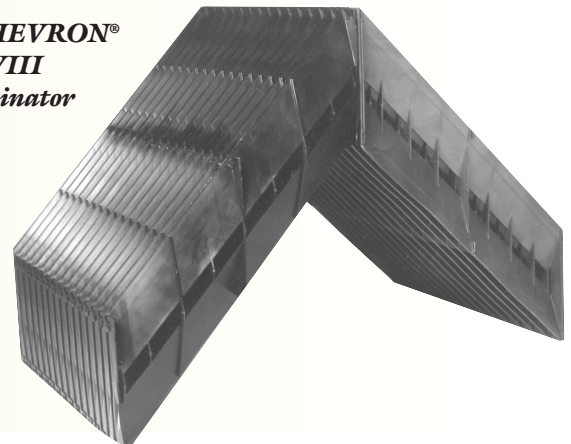

**FLEXICHEVRON®
Style XXVIII
Mist Eliminator**

How do you Rate a FLEXICHEVRON®

By considering various force balances for detachment or shattering of droplets, and by considering the terminal velocity of the droplets so formed, it can be shown that reentrainment is controlled by a dimensional reentrainment number:

$$Rn = \frac{F_s^4}{\sigma \rho_g}$$

where:

F_s = F Factor based on superficial velocity = $U_g \sqrt{\rho_g}$

σ = liquid surface tension

ρ_l = liquid density

g = acceleration of gravity

U_g = superficial gas velocity

ρ_g = gas density

Reentrainment will occur if Rn is above a certain critical value. In practice, the critical value of Rn can be determined by measuring the critical velocity for the

chevron of interest with an air-water system at ambient conditions. From the critical velocity, above which reentrainment occurs, and the known physical properties of the air-water system, $(F_s)_{critical}$ and $(Rn)_{critical}$ can be determined. The critical reentrainment number can then be applied to other systems or conditions to determine the maximum capacity for a given chevron.

Unfortunately, the difference between droplet penetration and reentrainment is often misunderstood. Droplets that penetrate the chevron are too small to be effectively removed by impaction. On the other hand, reentrained droplets are generally quite large and originate from droplets that have coalesced on the chevron blades. At high gas velocities, a chevron can have removal efficiency of 100% and simultaneously reentrain extensively. Conversely, at low gas velocities, the chevron may not reentrain but has poor removal. **Optimal chevron performance is achieved at a gas velocity that is as high as possible but not so high that it yields reentrainment.** It is a challenge for design engineers to develop chevron blade profiles for which the critical velocity is as high as possible.

FLEXICHEVRON® Mist Eliminators

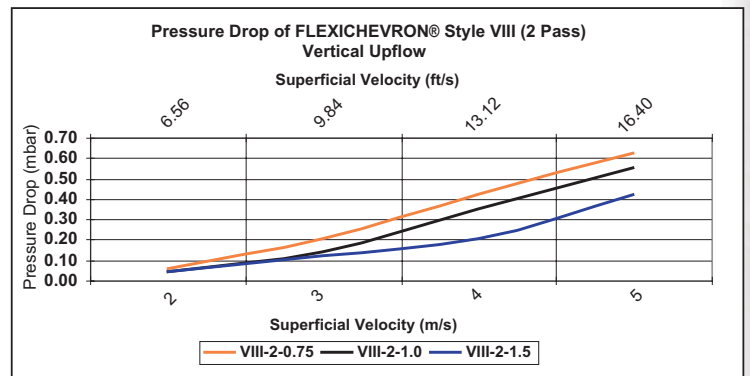
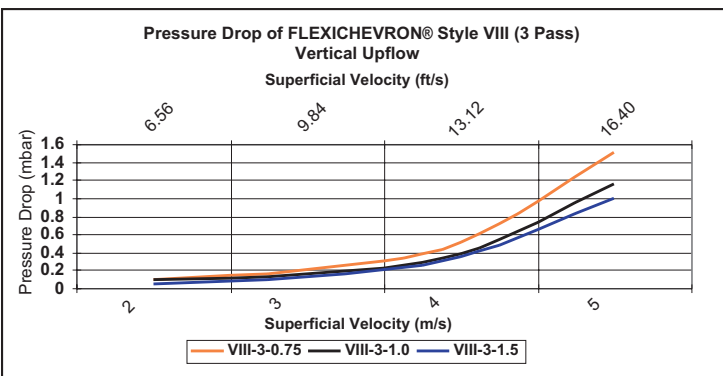
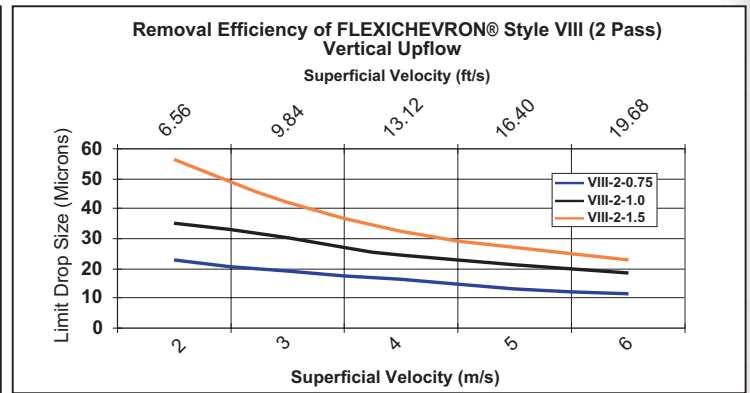
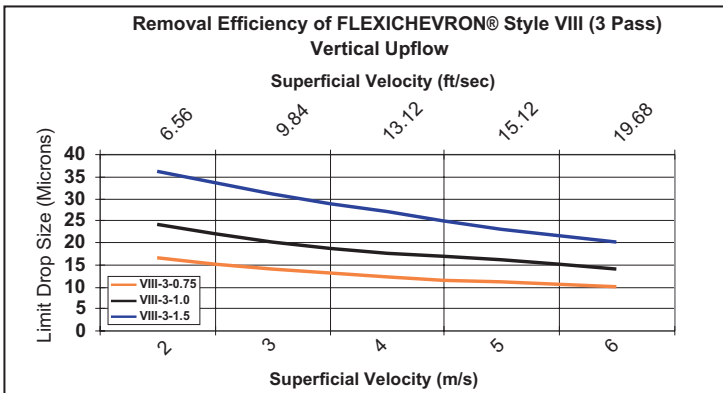

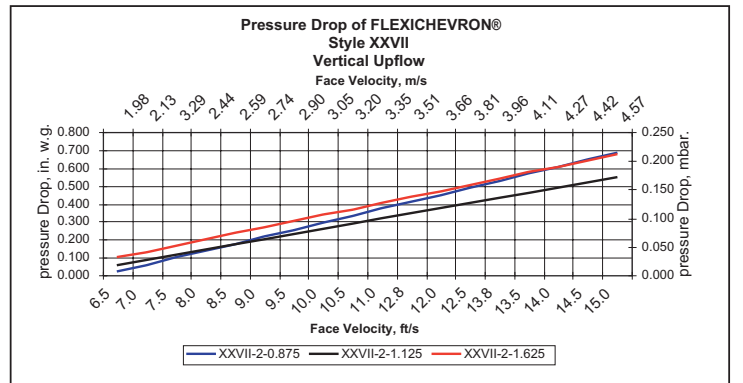
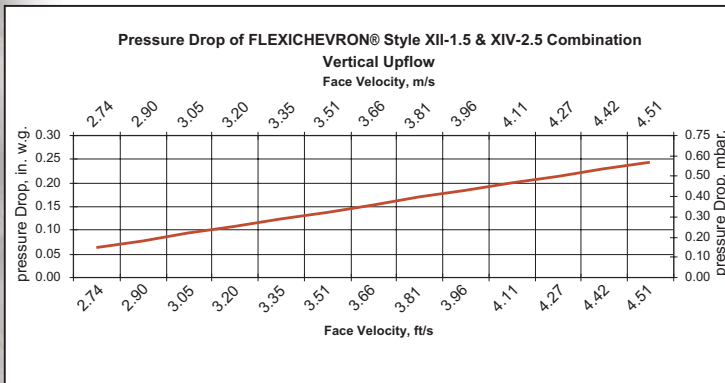
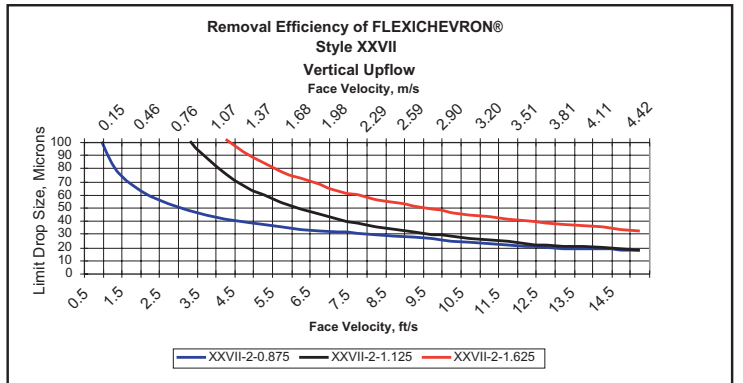
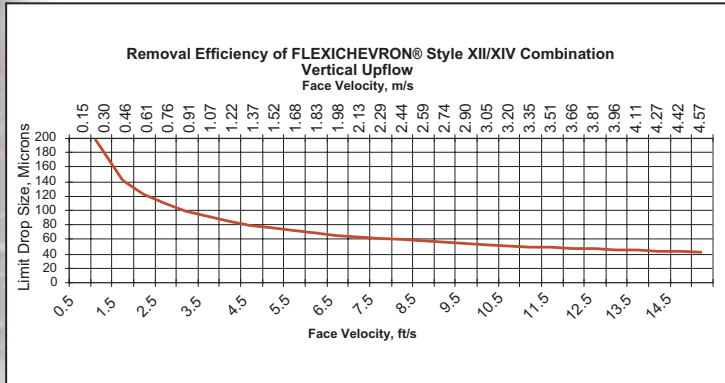
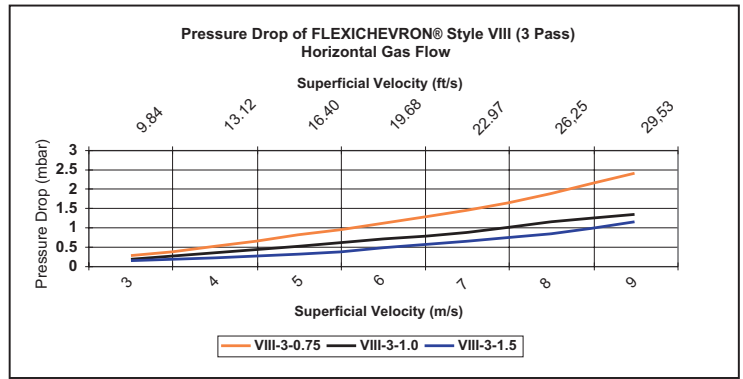
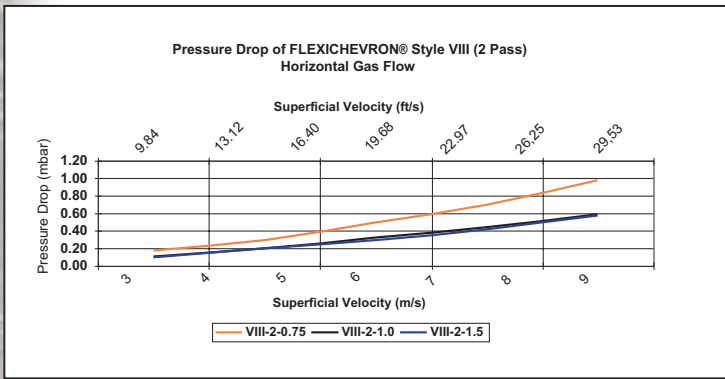

FLEXICHEVRON® HIERARCHY

DECREASING ΔP

Style XII/XIV
Style VIII (3-Pass)
Style XXVII
Style VIII (2-Pass)

INCREASING EFFICIENCY

Style VIII (3-Pass)
Style XXVII
Style XII/XIV
Style VIII (2-Pass)

INCREASING CAPACITY

Style XII/XIV
Style XXVII
Style VIII (2-Pass)
Style VIII (3-Pass)

Mist Measurement and Conformation of Mist Elimination Performance

Koch-Otto York routinely supplies the services for measuring the overall performance of the mist eliminator. This is done using the Phase Doppler Particle Analyzer (PDPA) which is a sophisticated laser-based instrument capable of accurately measuring droplet size and velocity. The PDPA has been used in the field since 1992, at numerous Utility power plants and at scrubber supplier R&D facilities. The PDPA was determined to be the "most accurate measurement method tested" in a joint study involving the Electric Power Research Institute (EPRI).

PDPA Operation

The essence of the operation of the PDPA consists of a laser beam that is produced and split by a beam splitter to form two identical polarized laser beams. Two fiber optic conductors in a shielded cable convey these beams to the transmitter. The transmitter lens takes the two parallel laser beams and crosses them to form a "probe volume". The probe volume is ellipsoidal in shape, and the intersecting beams are in the vertical plane. A droplet passing through the probe volume acts as a spherical lens and scatter light by refraction and reflection.

A receiver intercepts a portion of the refracted light scattered by the droplet and directs it towards three photo detectors. The detectors are connected to fiber optic conductors to a photo detector unit, which converts the three light signals into three electronic signals that are processed to extract droplet velocity and droplet size information. The electronic signal appears on an oscilloscope as Gaussian (bell shaped) curves or waves. The signal processor measures the time between the peaks and valleys of the waves, compares it to amount of time the droplet is in the probe volume, and determines droplet velocity. The size of the droplet is determined by the phase shift between the signals from the three detectors. Raw data is collected in the form of histograms, both droplet diameter histograms and droplet velocity histograms. From these histograms, the data can be sorted to determine average values for droplet velocity, droplet size range, and overall liquid outlet volumes. Further technical details can be provided in the Koch-Otto York report, "Laser-based Instrument Measures Mist Eliminator Carryover", written by Dr. Ken McNulty.



Insertion of the PDPA into a FGD scrubber.

PDPA Droplet Dia Histogram

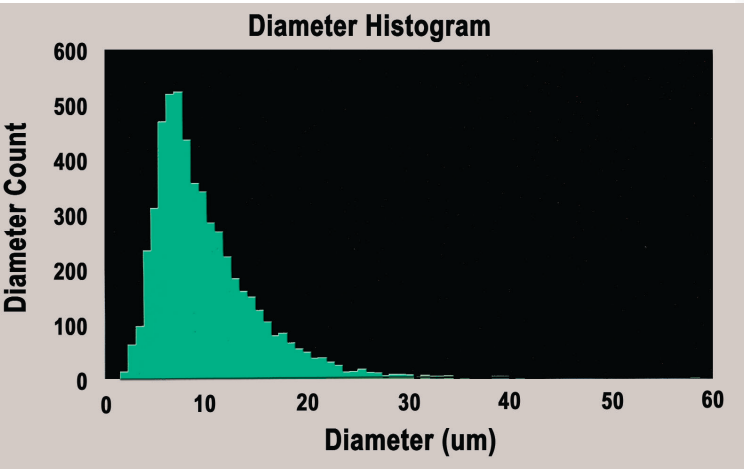

PDPA Droplet Velocity Histogram

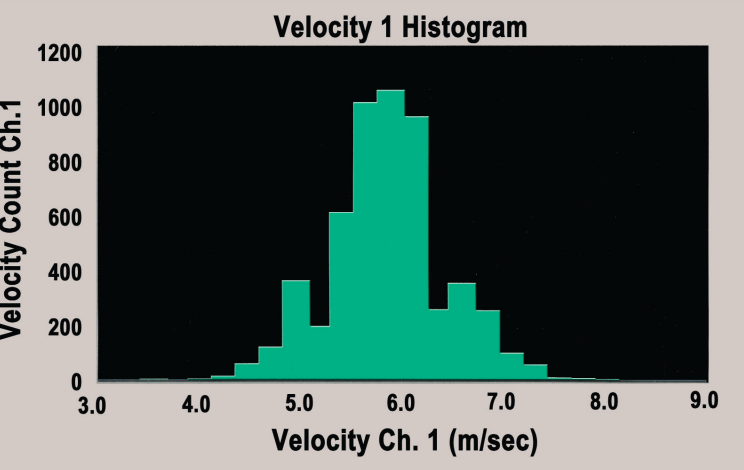

PDPA Measurement Verification

The PDPA was compared to other measurement methods in a test program sponsored by EPRI in 1994. The other two methods included a hot wire anemometer (AIMS) method, and, a MgO/treated paper method which measures the number and size of droplets by impaction. Direct moisture carryover was measured by the testing laboratory, and verified independent of the measurements taken by the PDPA. Neither team of operators knew the results obtained by the other. A third party independent contractor took the data from both teams and compared the results. This eliminated any possibility of collusion in the tests. Measurements were made with the PDPA in the outlet duct approximately 30"

above the chevron where the ducting narrowed. At this elevation, essentially all of the droplets entering the narrowed duct were carried over and collected downstream.

Table 1 shows the carryover as a function of velocity for both the independent testing laboratory and the PDPA. The accuracy demonstrated by the PDPA in the independently sponsored test program, is quite acceptable for commercial applications where the carryover can vary over orders of magnitude with velocity. The PDPA was $\pm 10\%$ of the direct carryover measurement. The MgO/treated paper was $\pm 23\%$, and the AIMS was $\pm 40\%$. The PDPA was also determined to have excellent repeatability.

Table 1 Comparison of Mist Eliminator Carryover as Measured by the PDPA and by Collection and Volumetric Measurement

Test	Mist Loading (gpm/ft ²)	Gas Velocity (ft/sec)	Volumetric Carryover (gpm/ft ²)	PDPA Carryover (gpm/ft ²)
1	1.5	12.07	0.0004	0.00046
2	1.5	15.26	0.0022	0.0018
3	1.5	17.07	0.038	0.052 (0.0431)
4	1.5	12.06	0.0005	0.00049

J.E. Lundeen, A.F. Jones, R.G. Rhudy, P. Bowen

"Evaluation of Mist Eliminator Carryover Measurement Methods for Full-Scale FGD Systems"

PDPA Field Testing & Site Preparation

The weight of the PDPA is approximately 45 lbs. and can be inserted into a 6" diameter port. The PDPA is typically suspended with taut 3/8" diameter steel cables, which will need to be installed prior to the test. A safe staging area (minimum 4 x 8 ft.) will be required at each test port to accommodate two technicians, instrument electronics, computer, and auxiliary equipment. Provisions should be made to minimize exposure to the elements due to the electronics required and calibration of the instrument once it arrives on site. A typical test will involve three days. The first day is devoted to transporting the equipment to the staging area, set-up, and aligning the optics.

The second day is devoted to actual absorber measurements. The third day is used for teardown and packing the equipment. Typically, five minutes worth of data will be accumulated at each test point, but can vary depending on the amount of moisture carryover. Raw data is many times available prior to the departure of the technicians, and a full technical report is issued 2-3 weeks after the test is complete.

Keeping you at the forefront of technology

Koch has strong commitment to research at our Research Center in Wichita, KS, where we are developing new mist eliminator designs and solving our customers' most complex problems. In FGD, Koch has continuing programs to develop lower pressure drop, higher capacity chevron designs, evaluate and optimize wash water system designs, analyzing absorber designs and to apply new methods to validate field performance using the Phase Doppler Particle Analyzer.



Using the Phase Doppler Particle Analyzer, performance data is taken in the horizontal flow test unit.



The 8ft. diameter test tower offers simulated performance in 1/8 scale.

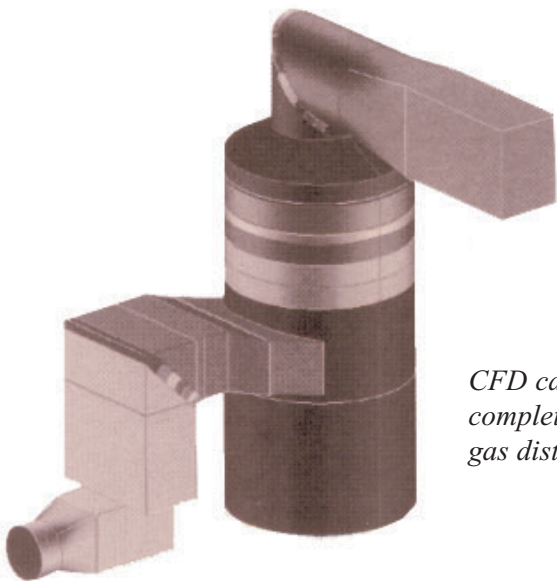

CFD capabilities allow Koch-Otto York to analyze the complete absorber package and ensure appropriate flue gas distribution through the mist eliminator.



KOCH-OTTO YORK®
Technology & Service
Leader in the Mist Elimination Industry.

**Members of the
Koch-Glitsch Business Group**

42 Intervale Road
P.O. Box 3100
Parsippany, NJ 07054-3100
TEL: 973-299-9200
800-524-1543
FAX: 973-299-9401

6611 Killough Road
Houston, TX 77086
TEL: 281-445-7026
800-736-7036
FAX: 281-445-7032

4111 E. 37th St. North
Wichita, KS 67220
TEL: 316-828-7181
FAX: 316-828-8018

Koch-Glitsch Italia S.r.l.
Koch-Otto York Division
V.le Cesare, 29
24124 Bergamo
Italy
SWITCHBOARD:
39-035-2273.411
TEL: 39-035-2273.563
FAX: 39-035-2273.400

Koch-Otto York BVBA
Bijkhoevelaan 12
B - 2110 Wijnegem, Belgium
TEL: 32-3-647-2847
FAX: 32-3-647-2879

Otto York Asia Pacific
260 Orchard Road, #11-01/09
The Heeren
Singapore 238855.
TEL: 65-831-6410
FAX: 65-835-2025

Visit us on the internet: www.koch-ottoyork.com



© 2002 KOCH-OTTO YORK®, A Koch-Glitsch Business Group
DEMISTER®, FLEXICHEVRON® and FLEXIFIBER® are
registered trademarks and YORKMESH™, YORK-EVENFLOW™ and
DEMISTER-PLUS™ are trademarks for our mist eliminators. SpiraFlow™
and CDS-Gasunie™ are trademarks of CDS Engineering.

All data in this brochure are for general information only and are based
on tests carried out under conditions which may or may not apply to your
requirements. No warranties or guarantees are expressed or implied. No
information contained in this brochure constitutes an invitation to infringe
any patent, whether now issued or issued hereafter. All descriptions and
specifications are subject to change without notice.