



KOCH-GLITSCH™



2013 Anniversary Reprint

This is a reprint of the 1993 Sixth Edition of the Glitsch BALLAST™ Tray Design Manual. It contains information considered to be accurate at the time of publication in 1993.

For the latest information on the design of towers, refer to the KG-TOWER™ software, which can be downloaded from <http://www.koch-glitsch.com/software>.

BALLAST[®] TRAY
DESIGN MANUAL
Bulletin 4900

Sixth Edition



GLITSCH INTERNATIONAL
World headquarters, Dallas

Look to Glitsch for . . .
Process Design of Trays and Tower Internals

. . . and you need look no further for Quality!



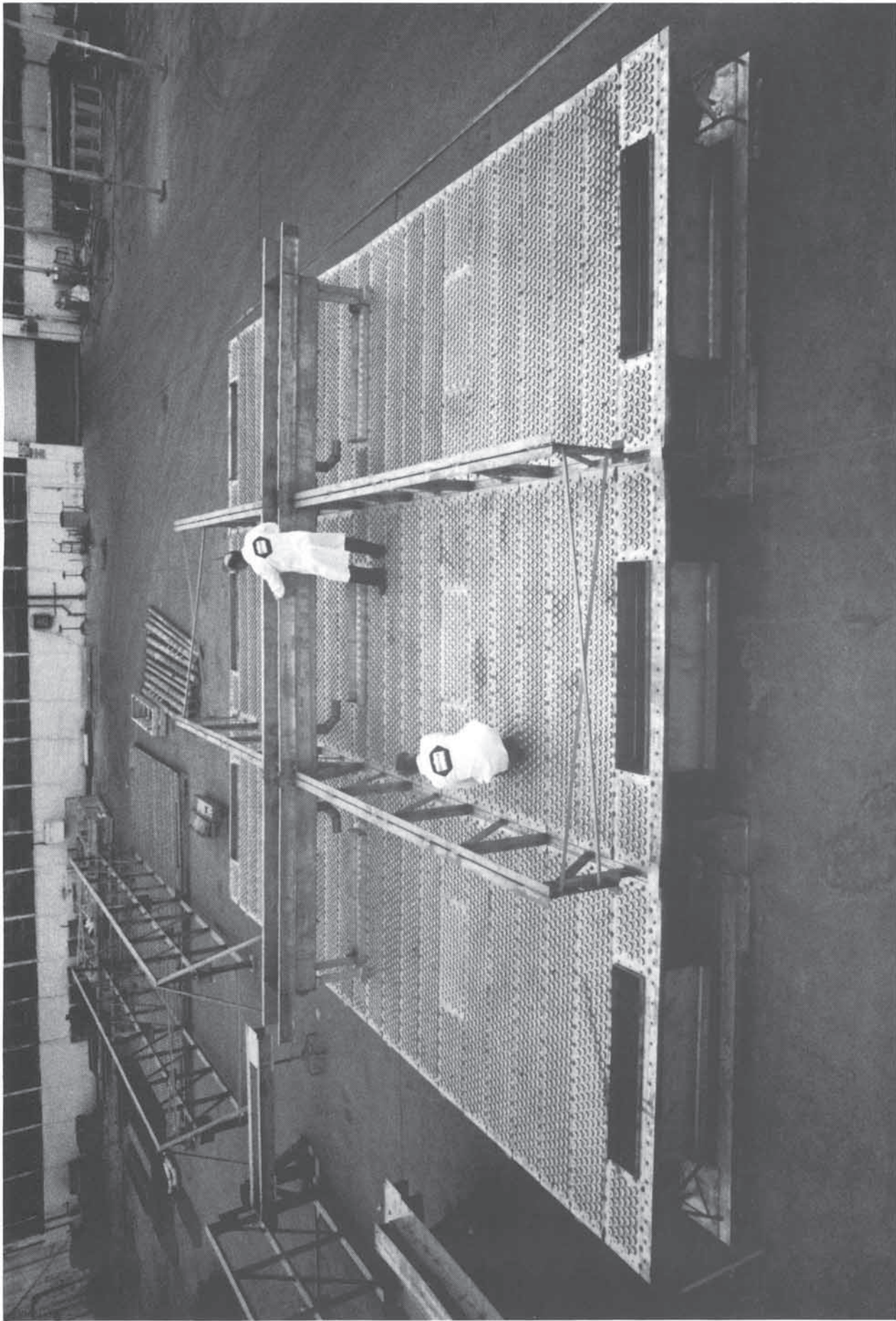

A-4 (low pressure drop) Ballast® Tray for SO₂ Absorber

To those using this manual . . .

This manual is a design procedure for Glitsch Ballast Trays. Certain aspects of tower design are important if maximum capacity is desired and potential bottlenecks are to be circumvented. In the initial phase of tower design, the following points should be considered when tray spacings are established:

1. Extra tray spacing usually is required at transition trays, i.e., where a change in the number of passes is contemplated. A spacing of 4'-0" is preferred, particularly in large towers.
2. Extra space is required if the feed is vaporized.
3. Extra space should be provided for internal liquid feed pipes if tower loadings are high at the feed point. Internal piping preferably is located at a point just below trusses of the next higher tray.

A column may flood prematurely for reasons other than tray design. The following are examples:

1. The liquid line to the reboiler is too small, becomes plugged with debris, or the reboiler vapor line is too small or otherwise restricted. Any of these may cause liquid to back up in the bottom of the column above the reboiler vapor line.
2. The reboiler vapor jet stream impinges on the seal pan overflow, resulting in excessive entrainment to the bottom tray.
3. A restriction to liquid flow through a downcomer exists due to incorrect tray installation or the presence of debris.
4. Reboiler or feed vapor improperly introduced.
5. Excessive foaming or vaporization of liquid in downcomer.
6. Internal loads are appreciably higher than design loads due to an incorrect latent heat of vaporization, a change in operating pressure, or not having made a proper heat and material balance.
7. Water, hydrates, or trace components such as glycol accumulate in the column to form a third phase. An occasional slug of methanol has been used to alleviate hydrate problems.
8. The system pressure is too close to the critical pressure.

The design procedure given herein is intended to be neither conservative nor optimistic. As design procedures for some valve type trays frequently indicate a "calculated" capacity which is higher than calculated by this design manual, it should be understood that Glitsch Ballast trays are guaranteed to have a capacity equal to, or greater than, any other conventional trays on the market.

Ballast[®] Tray Features

Webster has defined *ballast* for use in reference to “*that which needs to be held down because it is too light, too buoyant, or the like; it implies the addition of something heavy or solid enough to insure stability.*” During an early phase in research and development of Ballast trays, it was found that valves that were permitted to seat flush had a tendency to be unstable; i.e., at low vapor rates, the vapor would channel through a few wide-open valves in a small aerated zone located at some indeterminate position. The remaining valves would be completely closed. With flush seated units, liquid can bypass around the aerated zone on single pass trays; and on two pass trays, one side of the tray can be completely inactive, or the activity can switch back and forth from one side to the other. Glitsch has eliminated the problem of instability with various types of Ballast trays.

The Glitsch A-1 Ballast tray has a three-piece unit consisting of an orifice cover, Ballast plate and a travel stop. At extremely low vapor rates, the orifice cover rise is limited by the weight of the Ballast plate. When only the orifice covers are open, the slot area is relatively low which causes a larger portion of the capped area to be active. At higher vapor rates, the Ballast plate rises until it contacts the travel stop. The A-1 Ballast tray is very resistant to leakage and is highly recommended when the liquid rates are extremely low, or if the absolute maximum flexibility is required.

It is a valve type tray somewhat similar to the “rivet” tray first used in 1922. It differs from other valve type trays in three major respects. First, the V-1 unit has a two-stage slot opening rather than the single-stage conventionally used. This permits a flow of vapor through all of the valves at low vapor rates and results in a wide range of stable operating conditions. Second, the perimeter of the valve element is sloped downward and provided with a sharp edge at the lower portion of the lip. The sharp edge accentuates turbulence at the position where vapor enters the liquid and generates additional vapor-liquid interfacial area to give a high tray efficiency. Third, a heavy weight unit is normally used except in vacuum towers. The heavy unit increases the pressure drop and thereby increases tray efficiency in the operating region where the valves are not fully open.

Advantages of Ballast trays may be summarized as follows:

1. Maximum efficiency at low loads insures a minimum quantity of off-specification products during start-up. The high degree of flexibility makes it possible to operate with a minimum utility expense over a wide range of feed rates.
2. High efficiency at conditions 5 to 10 per cent below incipient flooding results in an increase in usable capacity. This permits more effective utilization of the column and auxiliary equipment.
3. High efficiency at intermediate load conditions can be utilized to improve product quality; to reduce the reflux ratio, resulting in a savings in utilities; or, to reduce the number of trays.

4. The combination of low pressure drop and high efficiency for vacuum systems means a lower tower pressure drop. The V-4 Ballast tray has been used to separate the ethylbenzene-styrene system in a single column.
5. The mechanical design of the tabs are such as virtually to eliminate sticking problems. No sticking problems have occurred in approximately 4000 process units and 30,000 columns of V-type trays. Shutdown time is decreased, due to rapid draining. Maintenance is simplified and worker comfort is improved because the top of the disc is smooth and flat. There are no sharp projections above the tray deck.

At zero to relatively low vapor rates, the V-type unit is seated on three tabs which hold the disc above the deck by a distance of approximately 0.1". The 0.1" height is an optimum distance. A higher initial rise results in too much slot area for operation at low loads and a lower initial rise results in tray instability. The line of contact of the tab with the deck is a 90° edge which is provided in order to help prevent sticking from rust and corrosion. For special conditions, it may be desirable to permit *selected* Ballast units to seat completely. The tabs are omitted to accomplish this.

At high vapor rates, the unit rises vertically to a maximum clearance above the deck of approximately 0.32". At intermediate vapor rates, some units will be completely open and the others will be resting on the deck.

Ballast trays may be used in any clean service, and have been used in many services subject to severe fouling with excellent success. By experience in commercial columns where cleaning may be necessary, it has been found that Ballast trays stay on stream for much longer periods of time than do other trays in the same service.

The use of stainless steel decks and valves are recommended for services having H₂S present. Some customers prefer stainless for the valves and deck sections, but may use carbon steel for downcomers and tray components not touching the valve. Carbon steel or monel must be used in service where HF is present. Carbon steel decks have been used in approximately 60 per cent of all installations to date.

Carbon steel Glitsch Ballast units are only occasionally used for reasons of economy. They are not normally recommended because the sharp edge on the lip will be lost due to rusting prior to the initial start-up or at shutdowns. The sharp edge is worth 5 to 10 per cent in added tray efficiency.

NOTE: This publication contains statements, data and information intended to assist prospective users in the selection of the Glitsch equipment best suited to their needs. All technical data contained herein were developed under carefully controlled conditions which may not duplicate the user's actual process conditions. Therefore, nothing in this manual is to be deemed a warranty. Glitsch will be pleased to give appropriate warranties in its quotation and which will be incorporated into the user's purchase order.

Glitsch reserves the right to modify or improve these products without notice.

FIGURE 1
Ballast® Unit Types

Nomenclature used: X: Flush-seating B: Blanked H: Heavy



V-1, V-4

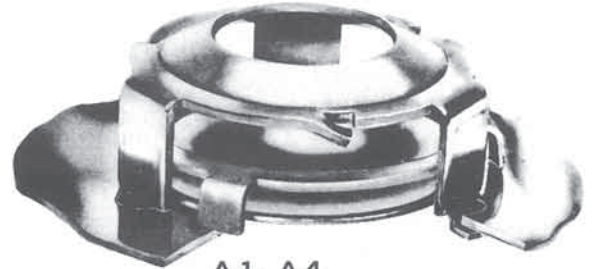

A-1, A-4

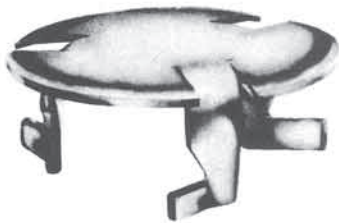

V-1X, V-4X

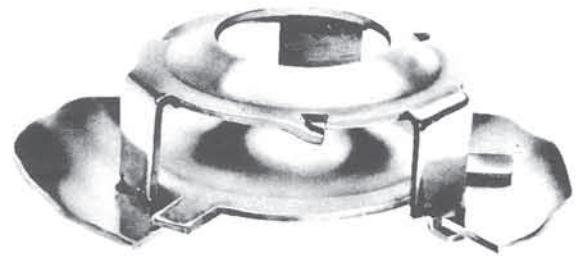

A-2X, A-5X

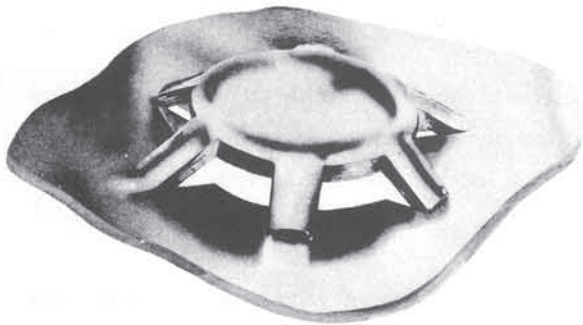

V-0

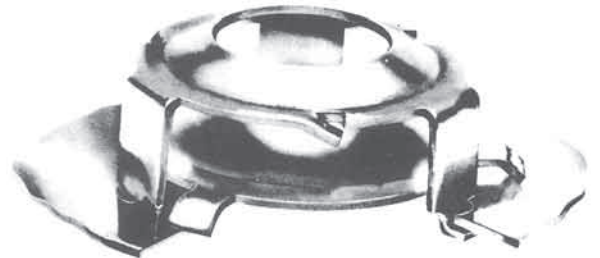

A-2, A-5

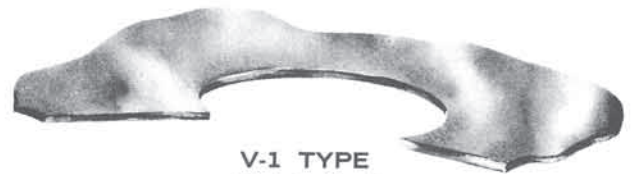

V-1 TYPE
(Flat Orifice)

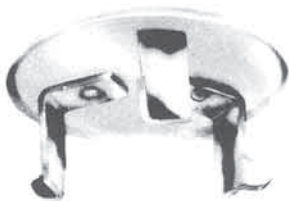

V-2X



V-4 TYPE
(Extruded Orifice)

Description of Ballast[®] Units

The various types of Ballast units are shown on the facing page. A description of each unit follows:

- V-0** A non-moving unit similar in appearance to the V-1 in a fully open position. It is used in services where only moderate flexibility is required and minimum cost is desired.
- V-1** A general purpose standard size unit, used in all services. The legs are formed integrally with the valve for deck thicknesses up to $\frac{3}{8}$ ".
- V-2** The V-2 unit is similar to the V-1 unit except the legs are welded-on in order to create a more leak-resistant unit. The welded legs permit fabrication of Ballast units for any deck thickness or size. Large size units are frequently used for replacement of bubble caps.
- V-3** A general purpose unit similar to the V-2 unit except the leg is radial from the cap center.
- V-4** This signifies a venturi-shaped orifice opening in the tray floor which is designed to reduce substantially the parasitic pressure drop at the entry and reversal areas. A standard Ballast unit is used in this opening normally, although a V-2 or V-3 unit can be used for special services. The maximum deck thickness permissible with this opening is 10 gage.
- V-5** A combination of V-0 and V-1 units. It normally is used where moderate flexibility is required and a low cost is essential.
- A-1** The original Ballast tray with a lightweight orifice cover which can close completely. It has a separate Ballast plate to give the two-stage effect and a cage or travel stop to hold the Ballast plate and orifice cover in proper relationship.
- A-2** The same as A-1, except the orifice cover is omitted.
- A-4** An A-1 unit combined with a venturi-shaped orifice opening in order to reduce the pressure drop.
- A-5** An A-2 unit combined with a venturi-shaped opening.

The diameter of the standard size of the V-series of Ballast units is $1\frac{7}{8}$ ". The V-2 and V-3 units are available in sizes up to 6".

Photographs of several Ballast trays are shown on page 8 and 9.

FIGURE 2

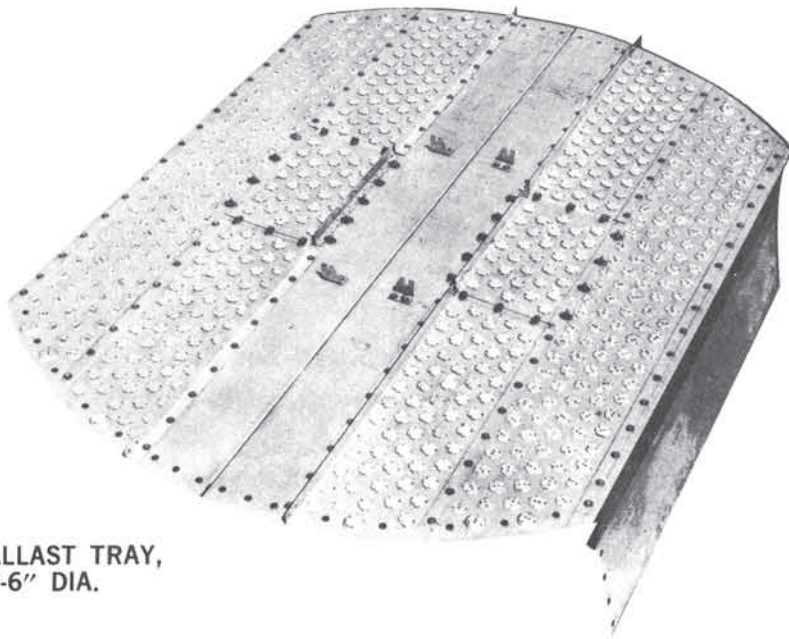

V-1 BALLAST TRAY,
9'-6" DIA.

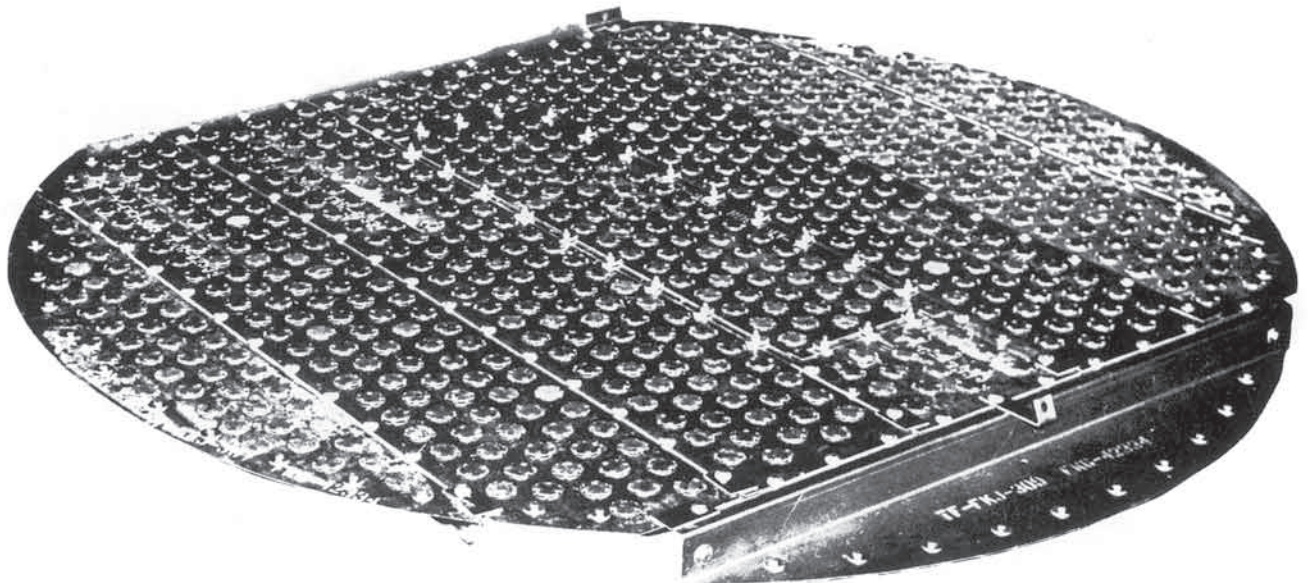

V-1 BALLAST TRAY
(with Recessed Inlet Sump)
10'-0" DIA.

FIGURE 3

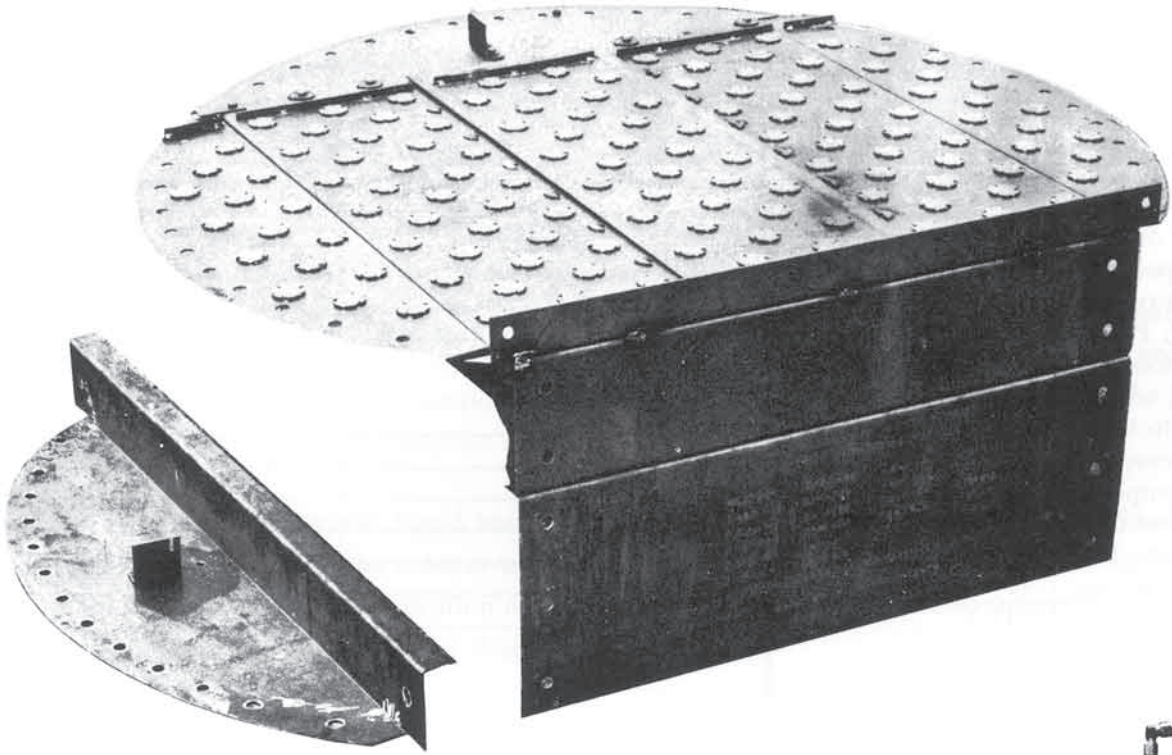

V-1 BALLAST TRAY,
5'-6" DIA.

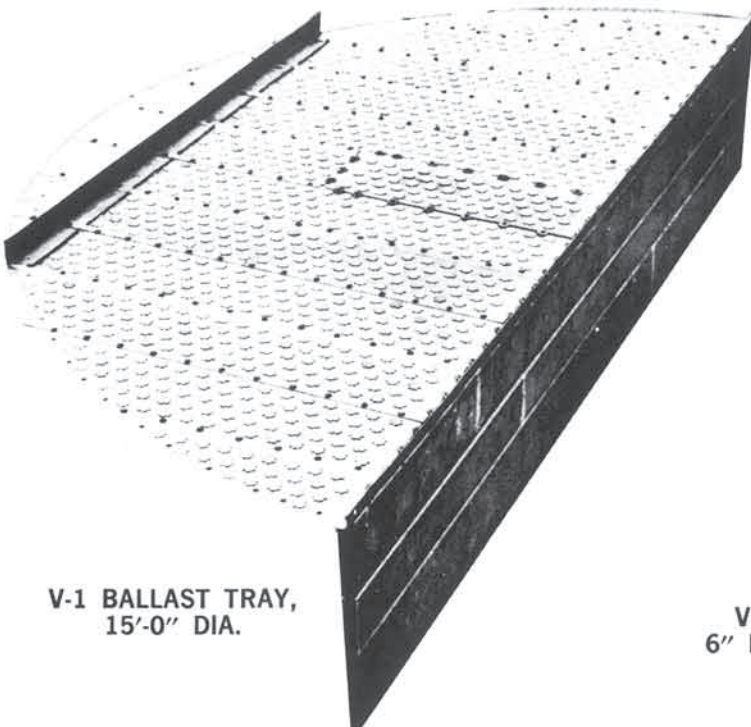

V-1 BALLAST TRAY,
15'-0" DIA.

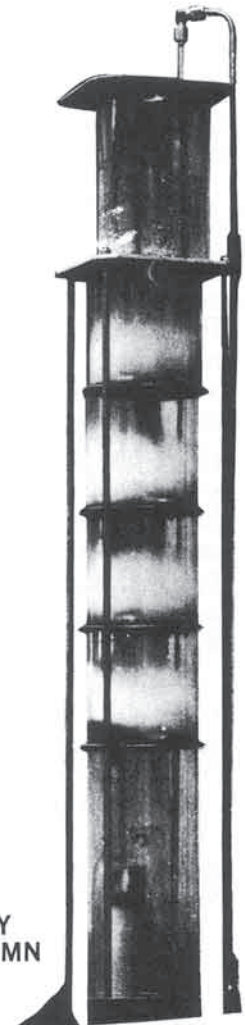

V-6 BALLAST TRAY
6" DIA. PILOT COLUMN

Process Design Data Sheet

Item No. or Service				
Tower diameter, I.D.				
Tray spacing, inches				
Total trays in section				
Max. ΔP , mm Hg				
Conditions at Tray No.				
Vapor to tray, °F				
Pressure,				
Compressibility				
*Density, lb./cu. ft.				
*Rate, lb./hr.				
cu. ft./sec. (cfs)				
$cfs \sqrt{D_v / (D_L - D_v)}$				
Liquid from tray, °F				
Surface tension				
Viscosity, cp				
*Density, lb./cu. ft.				
*Rate, lb./hr.				
GPM hot liquid				
Foaming tendency	None	Moderate	High	Severe

*These values are required in this form for direct computer input.

NOTES:

1. This form may be used for several sections of trays in one tower, for several towers, or for various loading cases. Use additional sheets if necessary.
2. Is maximum capacity at constant vapor-liquid ratio desired? _____
3. Minimum rate as % of design rate: _____%
4. Allowable downcomer velocity (if specified): _____ ft/sec
5. Number of flow paths or passes: _____ Glitsch Choice; _____
 Bottom tray downcomer: Total draw _____; Other _____
6. Trays numbered: top to bottom _____; bottom to top _____
7. Enclose tray and tower drawings for existing columns.
8. Manhole size, I.D., _____ inches.
9. Manways removable: top _____; bottom _____; top & bottom _____
10. Corrosion allowance: c.s. _____; other _____
11. Adjustable weirs required: yes _____ no _____
12. Packing material if required _____; not required _____
13. Tray material and thickness _____
14. Valve material _____
15. Ultimate user _____
16. Plant location _____
17. Other _____

Tray Design Information Required

Although it is possible to design valve trays based on only the internal vapor and liquid rates and densities, a more thorough design frequently can be obtained with complete information shown on the Process Design Data Sheet PE-8 (facing page). It is not necessary to provide all the information requested unless the system has properties different from those of conventional refinery and chemical separations. *However, a design which is more likely to give the desired separation, capacity, pressure drop and flexibility will be obtained if complete information is given. The amount of time required to fill in the form is negligible when the importance of complete information is recognized.*

It is important to have *internal* liquid and vapor loads at several tray locations if the loads vary appreciably from tray to tray. If the column is to be used in several different services, the loadings for each case should be calculated. An indication of minimum anticipated loads is also important. Minimum loads may be expressed as a percentage of design loads.

The type of service involved, or variety of services, should be given. Glycol dehydrators and amine absorbers are not designed by the same procedure as other service having identical densities and flow rates. If the system is frothy or has some other peculiar characteristic, the property should be described. Surface tension is an important physical property which should be given if available.

The allowable pressure drop, if specified, should not be made more restrictive than necessary. Ballast trays can be designed for a very low pressure drop; however, an unnecessarily restrictive pressure drop limitation may reduce the number of trays to a point where the desired separation cannot be obtained without going to two or more towers in series.

Frequently, an existing or specified tower diameter is larger than required. If a future increase in capacity is not contemplated, a less expensive design can be obtained by using larger downcomers than necessary, or by reducing the number of Ballast units. Many customers wish to utilize potential excess capacity. In order to obtain maximum capacity at constant vapor-liquid ratio, the ratio of downcomer area to active area is maintained for design conditions. This provides both adequate downcomer area and the proper active area for future increased loads. In most instances, the ultimate user will prefer a tray designed for maximum potential capacity rather than one designed for minimum cost.

Adjustable weirs are not required for a majority of services. They will not be used unless specified by the customer or required by process conditions.

Packing is not ordinarily required except in sumps and at the ends of trusses. The packing material is important for unusual services.

Design Procedure

Ballast trays are designed by a simple procedure. A diameter and tray spacing are estimated. The capacity, pressure drop and flexibility of a modular layout in that diameter are compared to customer specifications. A change in diameter, downcomer dimensions, cap spacing or tray spacing can then be made to meet specifications, to obtain a minimum cost design, or to obtain an optimum design, i.e., a design having maximum capacity and maximum efficiency.

Design Basis

Although it may be feasible to operate columns at near flood conditions, it is not possible to design them with a small safety factor and rely on them to always have the desired capacity and efficiency, whether guaranteed or not.

It has been a common practice of the industry to derate the calculated flood capacity for particular systems. For example, high pressure deethanizers have been known from experience to flood at say 60 per cent of the rate which might be obtained from an atmospheric column. Similarly, amine absorbers and glycol contactors might "carry-over" at say 70 per cent of calculated flood rates by some procedure.

The capacity procedure given in this manual accounts for the effect of high vapor density and foaming and no additional derating is necessary. In other words, a calculated per cent of flood of 100% means the tower can be expected to flood at design rates. By older methods, a calculated per cent of flood of say 60%, for a deethanizer as an example, might be equivalent to 100% of flood by the method given herein.

Flood Factor, FF

We recommend that new columns be sized so that design rates are no more than 82 per cent of flood rates. Some customers prefer a more liberal design in order to provide a contingency for process uncertainties. For example, a customer may specify that a column be capable of operating at 125 per cent of design rates. This implies a design at $.82/1.25$, or 66 per cent of flood as a maximum. An alternative would be to increase rates by a factor of 1.25 to obtain a new design basis.

The term FF, or flood factor, is used in certain equations for purposes of estimating column size. This term is the "design per cent of flood" expressed as a fraction. A value of not more than .77 is normally used for vacuum towers and a value of not more than .82 is used for other services. These values are intended to give not more than approximately 10% entrainment. Higher flood factors may result in excessive entrainment and/or a column sized too small for effective operation.

A flood factor of .65 to .75 should be used for column diameters under 36".

Downcomer Design Velocity, VD_{dsg}

Velocities used by various companies for sizing downcomers vary by a factor of more than two. Some companies use a residence time approach and others use a "maximum allowable velocity." Columns can be operated with a liquid velocity in the downcomer as high as 3 ft/sec provided the vapor rate is sufficiently low. This is about five times as high as the "maximum allowable" by most methods. Hence, the term "maximum allowable" can be misleading.

The procedure used in the manual for establishing downcomer area is based on a "design" velocity given by Figure 4 or Equation 1. The smallest value from Equation 1a, 1b or 1c is used. The "system factor" used in Equation 1 makes an allowance for foaming. If the designer knows that a particular system has a foaming tendency, an appropriate system factor should be applied. Factors for several typical services are shown in Table 1.

$$VD_{dsg} = 250 \times \text{System Factor} \quad (1a)$$

$$VD_{dsg} = 41 \times \sqrt{D_L - D_V} \times \text{System Factor} \quad (1b)$$

$$VD_{dsg} = 7.5 \times \sqrt{TS} \times \sqrt{D_L - D_V} \times \text{System Factor} \quad (1c)$$

where VD_{dsg} = Design velocity, gpm/sq. ft.

TS = Tray spacing, inches

TABLE 1a

Downcomer System Factors

Service	System Factor
Non foaming, regular systems	1.00
Fluorine systems, e.g., BF_3 , Freon90
Moderate foaming, e.g., oil absorbers, amine and glycol regenerators85
Heavy foaming, e.g., amine and glycol absorbers73
Severe foaming, e.g., MEK units60
Foam-stable systems, e.g., caustic regenerators30

FIGURE 4

Downcomer Design Velocity

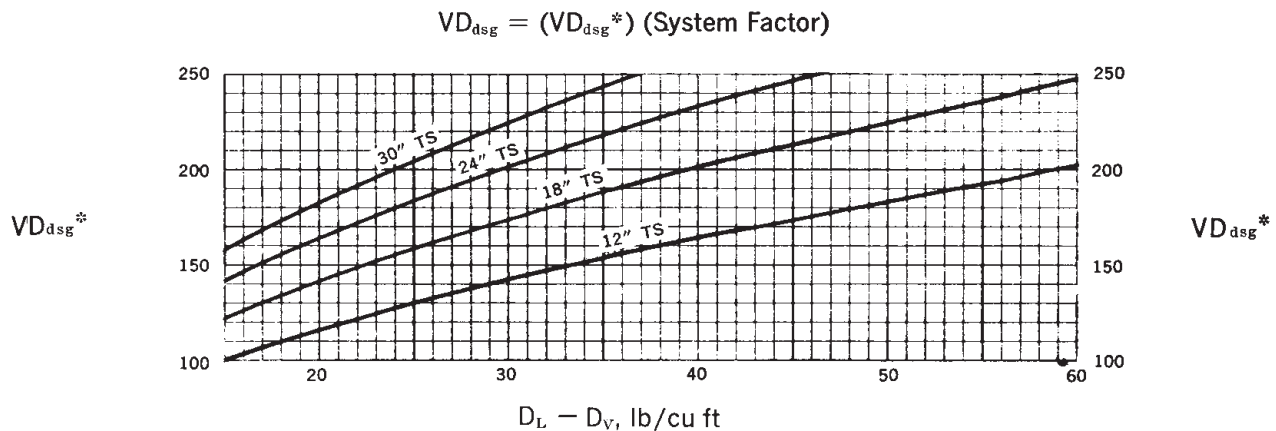

Vapor Capacity Factor, CAF

Figure 5 shows the vapor capacity factor of Ballast trays. The value of CAF₀ from Figure 5 is multiplied by a "system factor" given in Table 1b to obtain a value corrected for foaming.

$$\text{CAF} = \text{CAF}_0 \times \text{System Factor} \quad (2a)$$

The system factor used in Equation 2a is given below.

TABLE 1b
System Factors

<u>Service</u>	<u>System Factor</u>
Non-foaming, regular systems	1.00
Fluorine systems, e.g., BF ₃ , Freon90
Moderate foaming, e.g., oil absorbers, amine and glycol regenerators .85	
Heavy foaming, e.g., amine and glycol absorbers73
Severe foaming, e.g., MEK units60
Foam-stable systems, e.g., caustic regenerators30–.60

The capacity of Ballast trays increases with increasing tray spacing up to a limiting value. For practical purposes, the limit occurs at 48" for vapor densities below 4 lb/cu ft. Very high vapor density systems reach a limit at a tray spacing below 48". For example, a system having a vapor density of 7 lb/cu ft would have a capacity factor of 0.33 for any tray spacing above 18". Since a 24" tray spacing is generally selected for mechanical accessibility, this spacing could be used rather than 30" which might otherwise be considered.

The amount of energy dissipated by vapor flowing through a tray and the quantity of entrainment generated thereby increase with decreasing vapor density. In vacuum columns the amount of entrainment generated causes a reduction in the capacity factor from that which can be obtained with higher vapor densities. This effect is given by the equation shown as step 3 on Figure 5a.

Figure 5b is a coordinate plot showing the same relation given on Figure 5a. The limit point shown on Figure 5b can be exceeded at very high vapor densities for systems such as high pressure absorbers, where the liquid is not at its boiling point and where the liquid density is independent of the system pressure. Do not extrapolate the capacity values for liquid densities under approximately 35 lb/cu ft.

$$V_{\text{load}} = \text{CFS} \sqrt{D_v / (D_L - D_v)} \quad (2b)$$

where CFS = vapor rate, actual cu ft/sec

This term is used for sizing a column and for calculating per cent of flood for a given column diameter.

FIGURE 5a
FLOOD CAPACITY OF BALLAST TRAYS

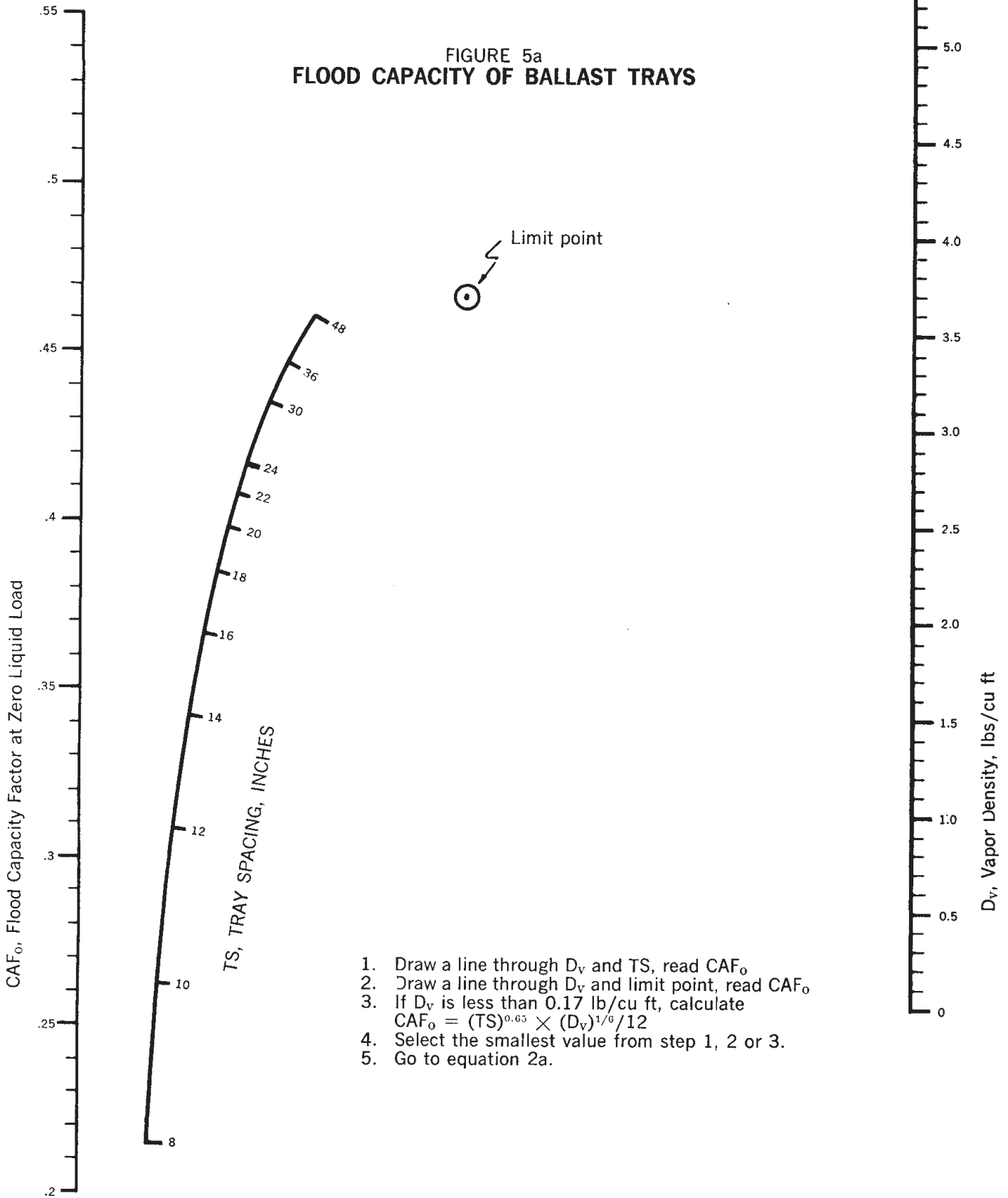

1. Draw a line through D_v and TS, read CAF₀
2. Draw a line through D_v and limit point, read CAF₀
3. If D_v is less than 0.17 lb/cu ft, calculate
 $CAF_0 = (TS)^{0.65} \times (D_v)^{1/6} / 12$
4. Select the smallest value from step 1, 2 or 3.
5. Go to equation 2a.

FIGURE 5b

FLOOD CAPACITY OF BALLAST TRAYS

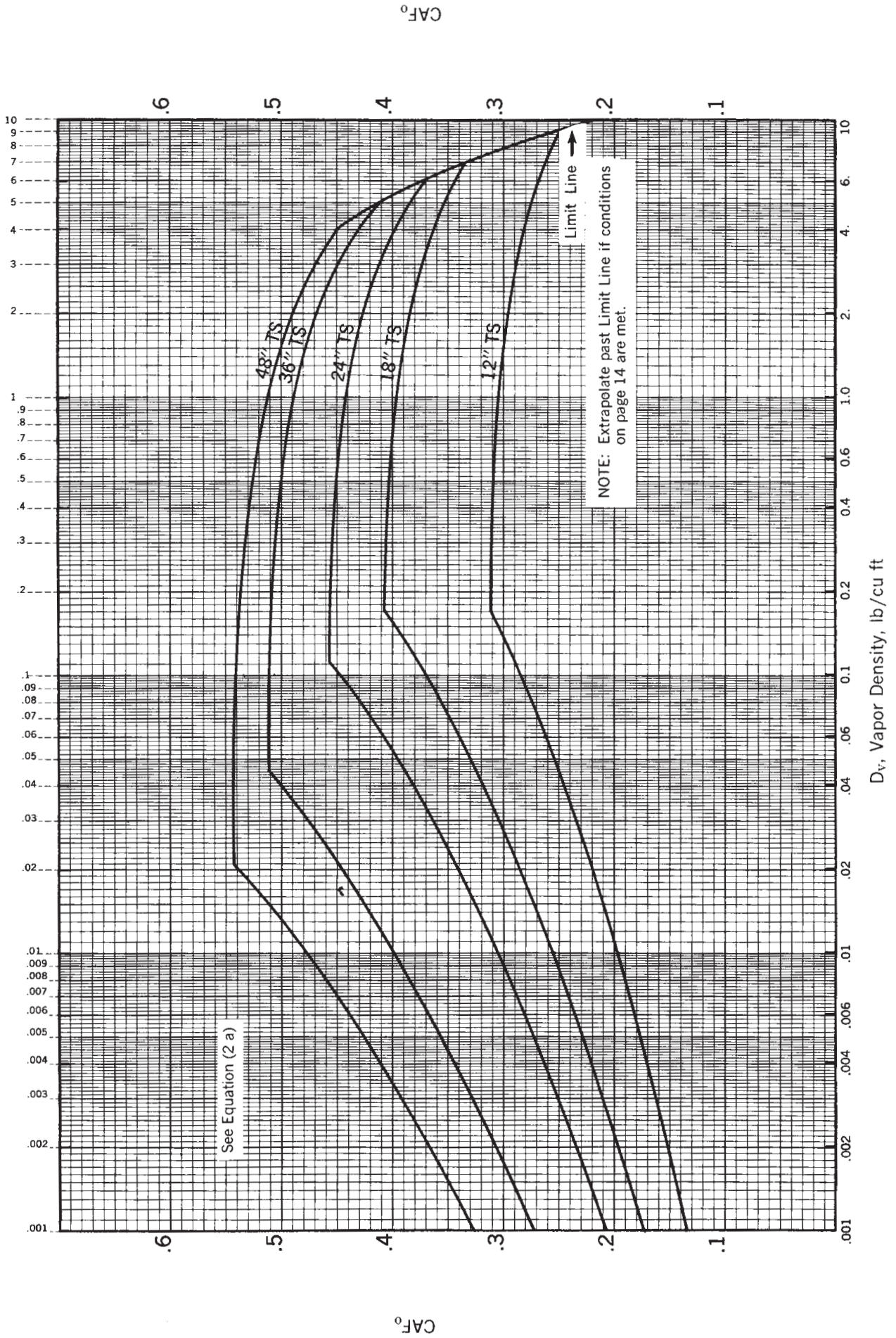
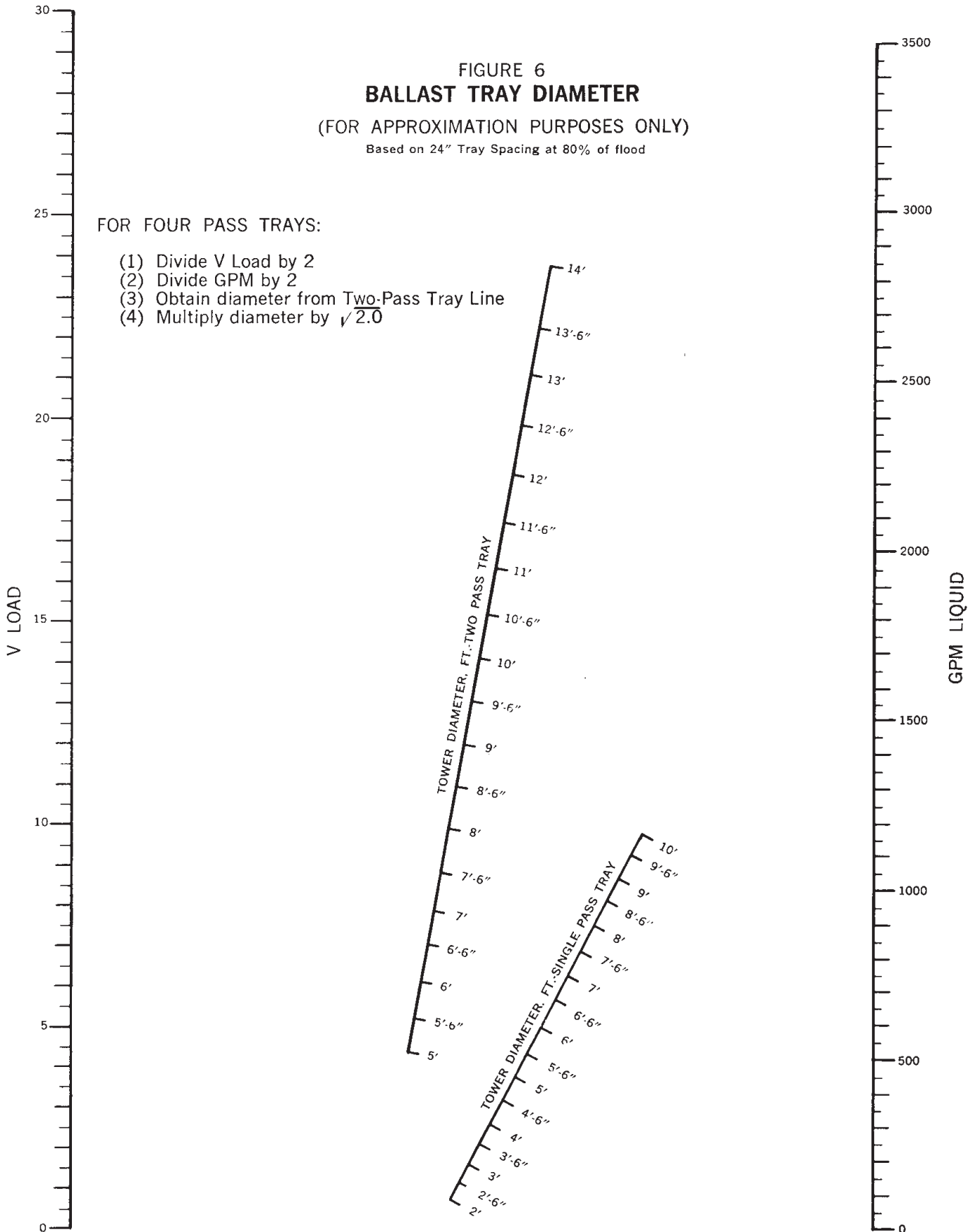

FIGURE 6
BALLAST TRAY DIAMETER
 (FOR APPROXIMATION PURPOSES ONLY)
 Based on 24" Tray Spacing at 80% of flood



FOR FOUR PASS TRAYS:

- (1) Divide V Load by 2
- (2) Divide GPM by 2
- (3) Obtain diameter from Two-Pass Tray Line
- (4) Multiply diameter by $\sqrt{2.0}$

Approximation of Column Diameter

Flow Path Length, FPL. An approximate flow path length is useful for establishing the minimum tower diameter. Figure 6 is used to obtain an approximation of tower diameter from which the flow path length can be estimated.

$$FPL = 9 \times DT/NP \quad (3)$$

where FPL = Flow path length, inches
DT = Tower diameter, feet
NP = Number of flow paths or passes

Active Area, AAM. The minimum active area is a function of vapor and liquid loads, system properties, flood factor and flow path length. Visual inspection of tray loadings usually will determine that tray which will give the largest active area.

$$AAM = \frac{Vload + GPM \times FPL/13000}{CAF \times FF} \quad (4)$$

where Vload = Vapor load for any tray in the section
GPM = Liquid load for the same tray
AAM = Minimum active area, sq. ft.
CAF = Capacity factor from Equation 2a
FF = Flood factor or design per cent of flood, fractional

Downcomer Area, ADM. The minimum downcomer area is a function of liquid rate, downcomer design velocity and flood factor. A visual inspection of liquid loads usually is sufficient to determine which tray requires the most downcomer area. The tray having the maximum liquid load is not necessarily the same one requiring the most active area.

$$ADM = GPM/(VD_{dsg} \times FF) \quad (5)$$

where VD_{dsg} = Downcomer velocity for design purposes, gpm/sq ft
ADM = Minimum downcomer area, sq ft

If the downcomer area calculated by Equation 5 is less than 11% of the active area, use the smaller of the following:

ADM = 11% of the active area, or
ADM = Double that by Equation 5

Column Area. The approximate column cross sectional area is calculated by Equation 6a or 6b. The larger value is used. A tower diameter based on the approximate column area is used as a starting point for more detailed calculations. Further design calculations may result in a change in tower diameter.

$$ATM = AAM + 2 \times ADM \quad (6a)$$

$$\text{or } ATM = \frac{Vload}{.78 \times CAF \times FF} \quad (6b)$$

$$DT = \sqrt{ATM/.7854} \quad (7)$$

where ATM = Minimum column cross sectional area, sq ft

Allocation of Areas for a Fixed Column Diameter

The diameter of a column may be estimated by Equation 7, or it may be some other value; e.g., an existing column diameter or one specified by the customer may be used. In any event, the actual cross sectional area of the diameter which is to be used is not likely to be the same as the approximate minimum by Equation 6.

If the actual tower cross sectional area is less than the calculated minimum area, a design for maximum capacity should be used; if it is greater than the calculated minimum, a design for either minimum cost or maximum capacity may be used.

Minimum Cost Design is obtained by making the active area equal to the minimum active area. The remaining tower area is devoted to downcomer area and downcomer seal area. For existing columns, it may be possible to reuse the existing downcomers at a savings, provided neither the downcomer area nor the active area is too small.

Maximum Capacity Design, one also giving maximum efficiency, is obtained by proportioning the active area and downcomer area so that the per cent of flood for vapor load is equal to the per cent of flood for liquid load. This type design is usually desired by the ultimate user; and, in the absence of specifications to the contrary, maximum capacity design is used by Glitsch for new columns. For maximum capacity design, the total downcomer area is calculated as follows:

$$AD = AT \times ADM/ATM \quad (8)$$

where AD = Total downcomer area, sq ft

AT = Actual tower area, sq ft

ADM = Minimum downcomer area by Equation 5

ATM = Minimum tower area by Equation 6

The downcomer area generally should not be less than 10% of the column area. However, if the liquid rate is unusually low, a downcomer area smaller than 10% of the column area may be used provided it is at least double the calculated minimum downcomer area.

Tray Sketch

Having established the tower diameter and downcomer area, a sketch of the tray is useful to establish other dimensions. Figure 7 shows typical sketches for one to five pass trays.

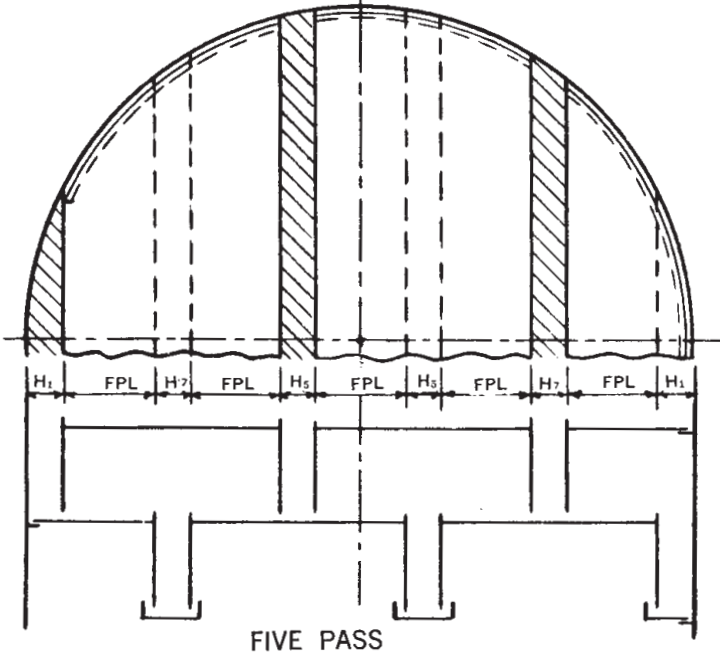
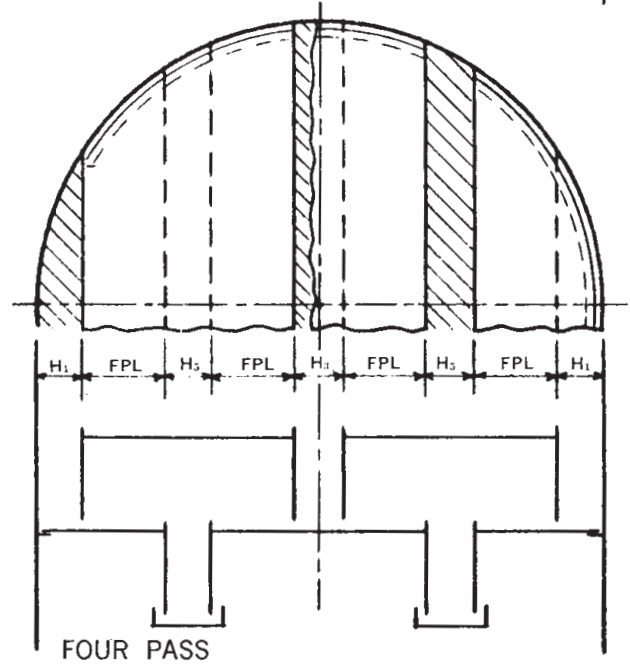
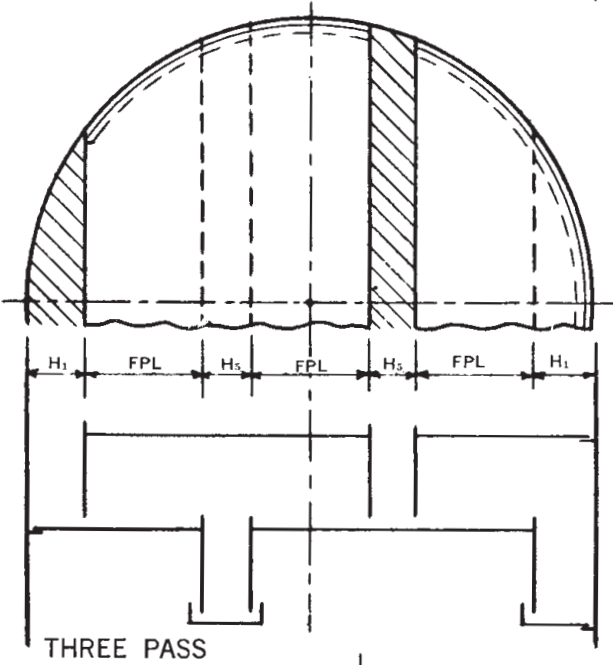
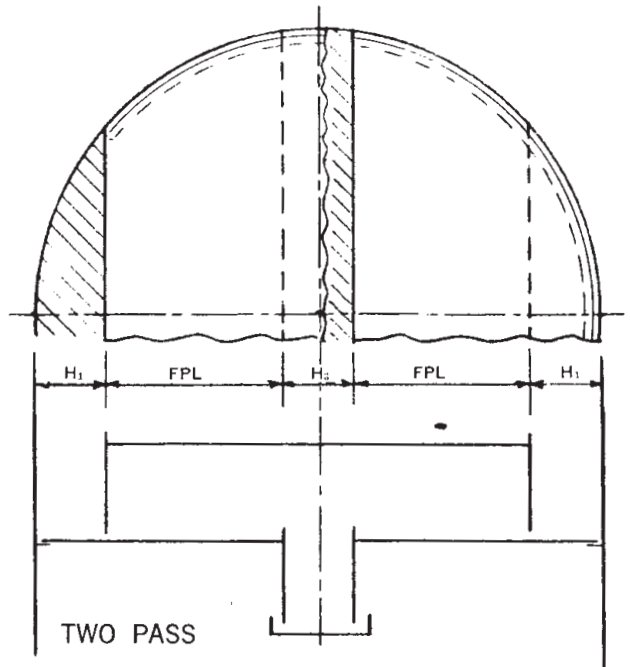
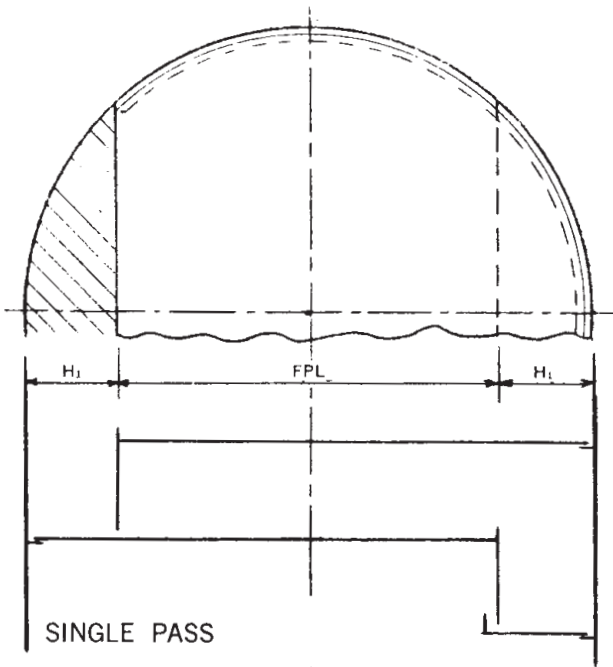

FIGURE 7
TRAY SKETCHES

Downcomer Widths, H

The terms H_1 , H_3 , H_5 and H_7 are used to designate the width in inches of the side, center, off-center and off-side downcomers, respectively. Corresponding areas at the top of downcomers are designated A_1 , A_3 , A_5 and A_7 , respectively. Refer to Figure 7. The total downcomer area should be divided between the downcomers of multipass trays in proportion to the liquid rate received and the active area served. For large diameter towers having three or more flow paths, the active area in each flow path should be equal and the weir lengths adjusted so that the liquid rate to each weir is the same. This may require the use of sweptback side downcomer weirs or sweptback side downcomers. Sweptback downcomers of the circular and segmental circular type are shown on page 34. Table 2 is useful for allocating downcomer area in accordance with this concept. For example, each of the side downcomers of a four-pass tray would have an area of approximately 25% of the total downcomer area.

TABLE 2
Allocation of Downcomer Area & Downcomer Width Factors

Passes	Fraction of Total Downcomer Area				Width Factors, WF		
	$\frac{AD_1}{AD}$	$\frac{AD_3}{AD}$	$\frac{AD_5}{AD}$	$\frac{AD_7}{AD}$	$\frac{H_1}{H}$	$\frac{H_3}{H}$	$\frac{H_5}{H}$
2	.50 ea.	1.00	—	—	12.0	—	—
3	.34	—	.66	—	—	8.63	—
4	.25 ea.	.50	.50 ea.	—	6.0	6.78 ea.	—
5	.20	—	.40	.40	—	5.66	5.5

The width of side downcomers can be obtained from Table 4. An accurate estimate of the width of other than a side downcomer can be obtained by substituting width factors from Table 2 in Equation 9.

$$H_i = WF \times AD/DT \quad (9)$$

where H_i = Width of individual downcomer, inches

AD = Total downcomer area, sq. ft.

DT = Tower diameter, ft.

WF = Width factor from Table 2

Downcomer widths are usually adjusted to give a modular flow path length. For preliminary purposes, the flow path length can be made equal to 8.5" plus a multiple of 1.5". The flow path length is calculated by Equation 10 and then downcomer widths may be adjusted to give a modular FPL.

$$FPL = \frac{12 \times DT - (2H_1 + H_3 + 2H_5 + 2H_7)}{NP} \quad (10)$$

where NP = Number of passes

A flow path length of less than 16" is not feasible if internal manways are required. Some services have such a high liquid load relative to the vapor load that the flow path length minimum of 16" may make it necessary to use a larger tower diameter than that calculated by Equation 7. For this condition, the minimum required downcomer area and the minimum flow path length establish the least cost design.

Downcomer Area, AD

With downcomer widths adjusted to modular dimensions, or established by other considerations, actual downcomer areas can be calculated exactly by use of Table 4. Alternately, the area of the center, off-center or off-side downcomers can be calculated with sufficient accuracy for preliminary purposes by use of the following equation:

$$AD_i = H_i \times SF \times DT/12 \quad (11)$$

where AD_i = Area of individual downcomer, sq ft
 H_i = Width of individual downcomer, inches
 SF = Span factor, fractional
 DT = Tower diameter, ft

The span factor used in the above equation is the wall-to-wall distance at the mid-point of a downcomer, expressed as a fraction of tower diameter. Table 3 gives span factors. This table is also useful for estimating weir lengths and for checking exact methods for both downcomer area and weir length.

TABLE 3
 Approximate Downcomer Span Factors, SF

Passes	Fraction of Tower Diameters		
	H_3	H_5	H_7
2	1.0	—	—
3	—	.95	—
4	1.0	.885	—
5	—	.98	.88

The downcomer area of even-numbered trays may be somewhat different from that of odd-numbered trays for two or four passes. An average value may be used as the total downcomer area for further calculations.

Active Area, AA

Active area is the area available for Ballast units between inlet and outlet edges of the tray. Either of the following two equations apply for straight downcomers or sloped downcomers with recessed inlets.

$$AA = AT - (2AD_1 + AD_3 + 2AD_5 + 2AD_7) \quad (12a)$$

$$AA = AT - 2 \times (AD_{avg}) \quad (12b)$$

where AD_{avg} is the average of the downcomer areas of odd-numbered and even-numbered trays. Sloped downcomers normally are used only with recessed inlet areas or draw sumps. The width and area of recessed inlets are usually the same as that at the top of the downcomers. Sloped downcomers with flat seal areas at the bottom are used when it is necessary to obtain additional Ballast units for decreasing the pressure drop. The additional active area which can be obtained by this type of downcomer design usually is not more than 50% of the downcomer area.

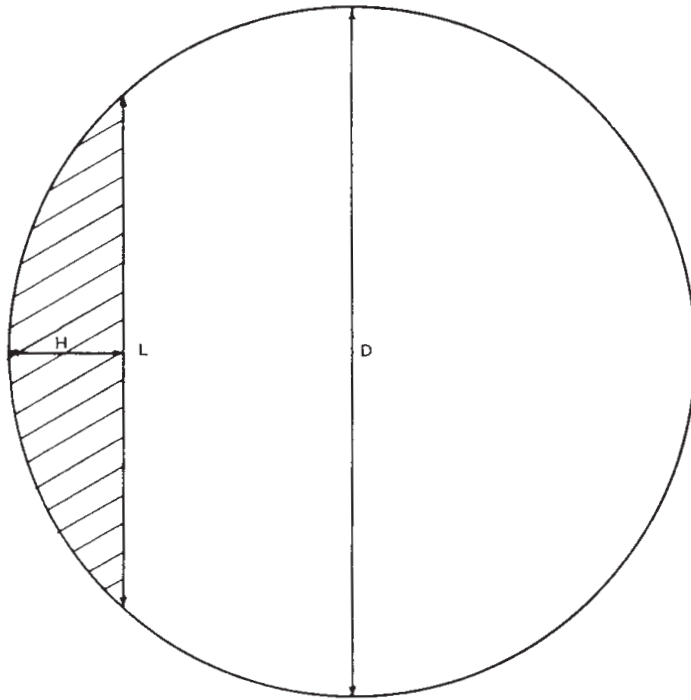

**TABLE 4
SEGMENTAL FUNCTIONS**

D = TOWER DIAMETER
H = CHORD HEIGHT
L = CHORD LENGTH
A_D = CHORD AREA
A_T = TOWER AREA

			H/D FROM .0 TO .1											
H/D	L/D	A _D /A _T	H/D	L/D	A _D /A _T	H/D	L/D	A _D /A _T	H/D	L/D	A _D /A _T	H/D	L/D	A _D /A _T
.0000	.0000	.0000	.0200	.2800	.0048	.0400	.3919	.0134	.0600	.4750	.0245	.0800	.5426	.0375
.0005	.0447	.0000	.0205	.2834	.0050	.0405	.3943	.0137	.0605	.4768	.0248	.0805	.5441	.0378
.0010	.0632	.0001	.0210	.2868	.0051	.0410	.3966	.0139	.0610	.4787	.0251	.0810	.5457	.0382
.0015	.0774	.0001	.0215	.2901	.0053	.0415	.3989	.0142	.0615	.4805	.0254	.0815	.5472	.0385
.0020	.0894	.0002	.0220	.2934	.0055	.0420	.4012	.0144	.0620	.4823	.0257	.0820	.5487	.0389
.0025	.0999	.0002	.0225	.2966	.0057	.0425	.4035	.0147	.0625	.4841	.0260	.0825	.5502	.0392
.0030	.1094	.0003	.0230	.2998	.0059	.0430	.4057	.0149	.0630	.4859	.0263	.0830	.5518	.0396
.0035	.1181	.0004	.0235	.3030	.0061	.0435	.4080	.0152	.0635	.4877	.0266	.0835	.5533	.0399
.0040	.1262	.0004	.0240	.3061	.0063	.0440	.4102	.0155	.0640	.4895	.0270	.0840	.5548	.0403
.0045	.1339	.0005	.0245	.3092	.0065	.0445	.4124	.0157	.0645	.4913	.0273	.0845	.5563	.0406
.0050	.1411	.0006	.0250	.3122	.0067	.0450	.4146	.0160	.0650	.4931	.0276	.0850	.5578	.0410
.0055	.1479	.0007	.0255	.3153	.0069	.0455	.4168	.0162	.0655	.4948	.0279	.0855	.5592	.0413
.0060	.1545	.0008	.0260	.3183	.0071	.0460	.4190	.0165	.0660	.4966	.0282	.0860	.5607	.0417
.0065	.1607	.0009	.0265	.3212	.0073	.0465	.4211	.0168	.0665	.4983	.0285	.0865	.5622	.0421
.0070	.1667	.0010	.0270	.3242	.0075	.0470	.4233	.0171	.0670	.5000	.0288	.0870	.5637	.0424
.0075	.1726	.0011	.0275	.3271	.0077	.0475	.4254	.0173	.0675	.5018	.0292	.0875	.5651	.0428
.0080	.1782	.0012	.0280	.3299	.0079	.0480	.4275	.0176	.0680	.5035	.0295	.0880	.5666	.0431
.0085	.1836	.0013	.0285	.3328	.0081	.0485	.4296	.0179	.0685	.5052	.0298	.0885	.5680	.0435
.0090	.1889	.0014	.0290	.3356	.0083	.0490	.4317	.0181	.0690	.5069	.0301	.0890	.5695	.0439
.0095	.1940	.0016	.0295	.3384	.0085	.0495	.4338	.0184	.0695	.5086	.0304	.0895	.5709	.0442
.0100	.1990	.0017	.0300	.3412	.0087	.0500	.4359	.0187	.0700	.5103	.0308	.0900	.5724	.0446
.0105	.2039	.0018	.0305	.3439	.0090	.0505	.4379	.0190	.0705	.5120	.0311	.0905	.5738	.0449
.0110	.2086	.0020	.0310	.3466	.0092	.0510	.4400	.0193	.0710	.5136	.0314	.0910	.5752	.0453
.0115	.2132	.0021	.0315	.3493	.0094	.0515	.4420	.0195	.0715	.5153	.0318	.0915	.5766	.0457
.0120	.2178	.0022	.0320	.3520	.0096	.0520	.4441	.0198	.0720	.5170	.0321	.0920	.5781	.0460
.0125	.2222	.0024	.0325	.3546	.0098	.0525	.4461	.0201	.0725	.5186	.0324	.0925	.5795	.0464
.0130	.2265	.0025	.0330	.3573	.0101	.0530	.4481	.0204	.0730	.5203	.0327	.0930	.5809	.0468
.0135	.2308	.0027	.0335	.3599	.0103	.0535	.4501	.0207	.0735	.5219	.0331	.0935	.5823	.0472
.0140	.2350	.0028	.0340	.3625	.0105	.0540	.4520	.0210	.0740	.5235	.0334	.0940	.5837	.0475
.0145	.2391	.0030	.0345	.3650	.0108	.0545	.4540	.0212	.0745	.5252	.0337	.0945	.5850	.0479
.0150	.2431	.0031	.0350	.3676	.0110	.0550	.4560	.0215	.0750	.5268	.0341	.0950	.5864	.0483
.0155	.2471	.0033	.0355	.3701	.0112	.0555	.4579	.0218	.0755	.5284	.0344	.0955	.5878	.0486
.0160	.2510	.0034	.0360	.3726	.0115	.0560	.4598	.0221	.0760	.5300	.0347	.0960	.5892	.0490
.0165	.2548	.0036	.0365	.3751	.0117	.0565	.4618	.0224	.0765	.5316	.0351	.0965	.5906	.0494
.0170	.2585	.0037	.0370	.3775	.0119	.0570	.4637	.0227	.0770	.5332	.0354	.0970	.5919	.0498
.0175	.2622	.0039	.0375	.3800	.0122	.0575	.4656	.0230	.0775	.5348	.0358	.0975	.5933	.0501
.0180	.2659	.0041	.0380	.3824	.0124	.0580	.4675	.0233	.0780	.5363	.0361	.0980	.5946	.0505
.0185	.2695	.0042	.0385	.3848	.0127	.0585	.4694	.0236	.0785	.5379	.0364	.0985	.5960	.0509
.0190	.2730	.0044	.0390	.3872	.0129	.0590	.4712	.0239	.0790	.5395	.0368	.0990	.5973	.0513
.0195	.2765	.0046	.0395	.3896	.0132	.0595	.4731	.0242	.0795	.5410	.0371	.0995	.5987	.0517

H/D FROM .1 TO .2

H/D	L/D	A _D /A _T	H/D	L/D	A _D /A _T	H/D	L/D	A _D /A _T	H/D	L/D	A _D /A _T	H/D	L/D	A _D /A _T
.1000	.6000	.0520	.1200	.6499	.0680	.1400	.6940	.0851	.1600	.7332	.1033	.1800	.7684	.1244
.1005	.6013	.0524	.1205	.6511	.0684	.1405	.6950	.0855	.1605	.7341	.1037	.1805	.7692	.1229
.1010	.6027	.0528	.1210	.6523	.0688	.1410	.6960	.0860	.1610	.7351	.1042	.1810	.7700	.1234
.1015	.6040	.0532	.1215	.6534	.0692	.1415	.6971	.0864	.1615	.7360	.1047	.1815	.7709	.1239
.1020	.6053	.0536	.1220	.6546	.0696	.1420	.6981	.0869	.1620	.7369	.1051	.1820	.7717	.1244
.1025	.6066	.0540	.1225	.6557	.0701	.1425	.6991	.0873	.1625	.7378	.1056	.1825	.7725	.1249
.1030	.6079	.0544	.1230	.6569	.0705	.1430	.7001	.0878	.1630	.7387	.1061	.1830	.7733	.1253
.1035	.6092	.0547	.1235	.6580	.0709	.1435	.7012	.0882	.1635	.7396	.1066	.1835	.7742	.1258
.1040	.6105	.0551	.1240	.6592	.0713	.1440	.7022	.0886	.1640	.7406	.1070	.1840	.7750	.1263
.1045	.6118	.0555	.1245	.6603	.0717	.1445	.7032	.0891	.1645	.7415	.1075	.1845	.7758	.1268
.1050	.6131	.0559	.1250	.6614	.0721	.1450	.7042	.0895	.1650	.7424	.1080	.1850	.7766	.1273
.1055	.6144	.0563	.1255	.6626	.0726	.1455	.7052	.0900	.1655	.7433	.1084	.1855	.7774	.1278
.1060	.6157	.0567	.1260	.6637	.0730	.1460	.7062	.0904	.1660	.7442	.1089	.1860	.7782	.1283
.1065	.6170	.0571	.1265	.6648	.0734	.1465	.7072	.0909	.1665	.7451	.1094	.1865	.7790	.1288
.1070	.6182	.0575	.1270	.6659	.0738	.1470	.7082	.0913	.1670	.7460	.1099	.1870	.7798	.1293
.1075	.6195	.0579	.1275	.6671	.0743	.1475	.7092	.0918	.1675	.7468	.1103	.1875	.7806	.1298
.1080	.6208	.0583	.1280	.6682	.0747	.1480	.7102	.0922	.1680	.7477	.1108	.1880	.7814	.1303
.1085	.6220	.0587	.1285	.6693	.0751	.1485	.7112	.0927	.1685	.7486	.1113	.1885	.7822	.1308
.1090	.6233	.0591	.1290	.6704	.0755	.1490	.7122	.0932	.1690	.7495	.1118	.1890	.7830	.1313
.1095	.6245	.0595	.1295	.6715	.0760	.1495	.7132	.0936	.1695	.7504	.1122	.1895	.7838	.1318
.1100	.6258	.0599	.1300	.6726	.0764	.1500	.7141	.0941	.1700	.7513	.1127	.1900	.7846	.1323
.1105	.6270	.0602	.1305	.6737	.0768	.1505	.7151	.0945	.1705	.7521	.1132	.1905	.7854	.1328
.1110	.6283	.0606	.1310	.6748	.0773	.1510	.7161	.0950	.1710	.7530	.1137	.1910	.7862	.1333
.1115	.6295	.0610	.1315	.6759	.0777	.1515	.7171	.0954	.1715	.7539	.1142	.1915	.7870	.1338
.1120	.6307	.0614	.1320	.6770	.0781	.1520	.7180	.0959	.1720	.7548	.1146	.1920	.7877	.1343
.1125	.6320	.0619	.1325	.6781	.0785	.1525	.7190	.0963	.1725	.7556	.1151	.1925	.7885	.1348
.1130	.6332	.0623	.1330	.6791	.0790	.1530	.7200	.0968	.1730	.7565	.1156	.1930	.7893	.1353
.1135	.6344	.0627	.1335	.6802	.0794	.1535	.7209	.0973	.1735	.7574	.1161	.1935	.7901	.1358
.1140	.6356	.0631	.1340	.6813	.0798	.1540	.7219	.0977	.1740	.7582	.1166	.1940	.7909	.1363
.1145	.6368	.0635	.1345	.6824	.0803	.1545	.7229	.0982	.1745	.7591	.1171	.1945	.7916	.1368
.1150	.6380	.0639	.1350	.6834	.0807	.1550	.7238	.0986	.1750	.7599	.1175	.1950	.7924	.1373
.1155	.6392	.0643	.1355	.6845	.0811	.1555	.7248	.0991	.1755	.7608	.1180	.1955	.7932	.1378
.1160	.6404	.0647	.1360	.6856	.0816	.1560	.7257	.0996	.1760	.7616	.1185	.1960	.7939	.1383
.1165	.6416	.0651	.1365	.6866	.0820	.1565	.7267	.1000	.1765	.7625	.1190	.1965	.7947	.1388
.1170	.6428	.0655	.1370	.6877	.0825	.1570	.7276	.1005	.1770	.7633	.1195	.1970	.7955	.1393
.1175	.6440	.0659	.1375	.6887	.0829	.1575	.7285	.1009	.1775	.7642	.1200	.1975	.7962	.1398
.1180	.6452	.0663	.1380	.6898	.0833	.1580	.7295	.1014	.1780	.7650	.1204	.1980	.7970	.1403
.1185	.6464	.0667	.1385	.6908	.0838	.1585	.7304	.1019	.1785	.7659	.1209	.1985	.7977	.1409
.1190	.6476	.0671	.1390	.6919	.0842	.1590	.7314	.1023	.1790	.7667	.1214	.1990	.7985	.1414
.1195	.6488	.0676	.1395	.6929	.0847	.1595	.7323	.1028	.1795	.7675	.1219	.1995	.7992	.1419

H/D FROM .2 TO .3

H/D	L/D	A _D /A _T	H/D	L/D	A _D /A _T	H/D	L/D	A _D /A _T	H/D	L/D	A _D /A _T	H/D	L/D	A _D /A _T
.2000	.8000	.1424	.2200	.8285	.1631	.2400	.8542	.1845	.2600	.8773	.2066	.2800	.8980	.2292
.2005	.8007	.1429	.2205	.8292	.1636	.2405	.8548	.1851	.2605	.8778	.2072	.2805	.8985	.2298
.2010	.8015	.1434	.2210	.8298	.1642	.2410	.8554	.1856	.2610	.8784	.2077	.2810	.8990	.2304
.2015	.8022	.1439	.2215	.8305	.1647	.2415	.8560	.1862	.2615	.8789	.2083	.2815	.8995	.2309
.2020	.8030	.1444	.2220	.8312	.1652	.2420	.8566	.1867	.2620	.8794	.2088	.2820	.8999	.2315
.2025	.8037	.1449	.2225	.8319	.1658	.2425	.8572	.1873	.2625	.8800	.2094	.2825	.9004	.2321
.2030	.8045	.1454	.2230	.8325	.1663	.2430	.8578	.1878	.2630	.8805	.2100	.2830	.9009	.2326
.2035	.8052	.1460	.2235	.8332	.1668	.2435	.8584	.1884	.2635	.8811	.2105	.2835	.9014	.2332
.2040	.8059	.1465	.2240	.8338	.1674	.2440	.8590	.1889	.2640	.8816	.2111	.2840	.9019	.2338
.2045	.8067	.1470	.2245	.8345	.1679	.2445	.8596	.1895	.2645	.8821	.2116	.2845	.9024	.2344
.2050	.8074	.1475	.2250	.8352	.1684	.2450	.8602	.1900	.2650	.8827	.2122	.2850	.9028	.2349
.2055	.8081	.1480	.2255	.8358	.1689	.2455	.8608	.1906	.2655	.8832	.2128	.2855	.9033	.2355
.2060	.8089	.1485	.2260	.8365	.1695	.2460	.8614	.1911	.2660	.8837	.2133	.2860	.9038	.2361
.2065	.8096	.1490	.2265	.8371	.1700	.2465	.8619	.1917	.2665	.8843	.2139	.2865	.9043	.2367
.2070	.8103	.1496	.2270	.8378	.1705	.2470	.8625	.1922	.2670	.8848	.2145	.2870	.9047	.2372
.2075	.8110	.1501	.2275	.8384	.1711	.2475	.8631	.1927	.2675	.8853	.2150	.2875	.9052	.2378
.2080	.8118	.1506	.2280	.8391	.1716	.2480	.8637	.1933	.2680	.8858	.2156	.2880	.9057	.2384
.2085	.8125	.1511	.2285	.8397	.1721	.2485	.8643	.1938	.2685	.8864	.2161	.2885	.9061	.2390
.2090	.8132	.1516	.2290	.8404	.1727	.2490	.8649	.1944	.2690	.8869	.2167	.2890	.9066	.2395
.2095	.8139	.1521	.2295	.8410	.1732	.2495	.8654	.1949	.2695	.8874	.2173	.2895	.9071	.2401
.2100	.8146	.1527	.2300	.8417	.1738	.2500	.8660	.1955	.2700	.8879	.2178	.2900	.9075	.2407
.2105	.8153	.1532	.2305	.8423	.1743	.2505	.8666	.1961	.2705	.8884	.2184	.2905	.9080	.2413
.2110	.8160	.1537	.2310	.8429	.1748	.2510	.8672	.1966	.2710	.8890	.2190	.2910	.9084	.2419
.2115	.8167	.1542	.2315	.8436	.1754	.2515	.8678	.1972	.2715	.8895	.2195	.2915	.9089	.2424
.2120	.8174	.1547	.2320	.8442	.1759	.2520	.8683	.1977	.2720	.8900	.2201	.2920	.9094	.2430
.2125	.8182	.1553	.2325	.8449	.1764	.2525	.8689	.1983	.2725	.8905	.2207	.2925	.9098	.2436
.2130	.8189	.1558	.2330	.8455	.1770	.2530	.8695	.1988	.2730	.8910	.2212	.2930	.9103	.2442
.2135	.8196	.1563	.2335	.8461	.1775	.2535	.8700	.1994	.2735	.8915	.2218	.2935	.9107	.2448
.2140	.8203	.1568	.2340	.8467	.1781	.2540	.8706	.1999	.2740	.8920	.2224	.2940	.9112	.2453
.2145	.8210	.1573	.2345	.8474	.1786	.2545	.8712	.2005	.2745	.8925	.2229	.2945	.9116	.2459
.2150	.8216	.1579	.2350	.8480	.1791	.2550	.8717	.2010	.2750	.8930	.2235	.2950	.9121	.2465
.2155	.8223	.1584	.2355	.8486	.1797	.2555	.8723	.2016	.2755	.8935	.2241	.2955	.9125	.2471
.2160	.8230	.1589	.2360	.8492	.1802	.2560	.8728	.2021	.2760	.8940	.2246	.2960	.9130	.2477
.2165	.8237	.1594	.2365	.8499	.1808	.2565	.8734	.2027	.2765	.8945	.2252	.2965	.9134	.2482
.2170	.8244	.1600	.2370	.8505	.1813	.2570	.8740	.2033	.2770	.8950	.2258	.2970	.9139	.2488
.2175	.8251	.1605	.2375	.8511	.1818	.2575	.8745	.2038	.2775	.8955	.2264	.2975	.9143	.2494
.2180	.8258	.1610	.2380	.8517	.1824	.2580	.8751	.2044	.2780	.8960	.2269	.2980	.9148	.2500
.2185	.8265	.1615	.2385	.8523	.1829	.2585	.8756	.2049	.2785	.8965	.2275	.2985	.9152	.2506
.2190	.8271	.1621	.2390	.8529	.1835	.2590	.8762	.2055	.2790	.8970	.2281	.2990	.9156	.2511
.2195	.8278	.1626	.2395	.8536	.1840	.2595	.8767	.2060	.2795	.8975	.2286	.2995	.9161	.2517

			H/D FROM .3 TO .4						H/D FROM .4 TO .5					
H/D	L/D	A _D /A _T	H/D	L/D	A _D /A _T	H/D	L/D	A _D /A _T	H/D	L/D	A _D /A _T	H/D	L/D	A _D /A _T
.3000	.9165	.2523	.3200	.9330	.2759	.3400	.9474	.2998	.3600	.9600	.3241	.3800	.9708	.3487
.3005	.9170	.2529	.3205	.9333	.2765	.3405	.9478	.3004	.3605	.9603	.3247	.3805	.9710	.3493
.3010	.9174	.2535	.3210	.9337	.2771	.3410	.9481	.3010	.3610	.9606	.3253	.3810	.9713	.3499
.3015	.9178	.2541	.3215	.9341	.2777	.3415	.9484	.3016	.3615	.9609	.3259	.3815	.9715	.3505
.3020	.9183	.2547	.3220	.9345	.2782	.3420	.9488	.3022	.3620	.9612	.3265	.3820	.9718	.3512
.3025	.9187	.2552	.3225	.9349	.2788	.3425	.9491	.3028	.3625	.9614	.3272	.3825	.9720	.3518
.3030	.9191	.2558	.3230	.9352	.2794	.3430	.9494	.3034	.3630	.9617	.3278	.3830	.9722	.3524
.3035	.9195	.2564	.3235	.9356	.2800	.3435	.9498	.3040	.3635	.9620	.3284	.3835	.9725	.3530
.3040	.9200	.2570	.3240	.9360	.2806	.3440	.9501	.3046	.3640	.9623	.3290	.3840	.9727	.3536
.3045	.9204	.2576	.3245	.9364	.2812	.3445	.9504	.3053	.3645	.9626	.3296	.3845	.9730	.3543
.3050	.9208	.2582	.3250	.9367	.2818	.3450	.9507	.3059	.3650	.9629	.3302	.3850	.9732	.3549
.3055	.9212	.2588	.3255	.9371	.2824	.3455	.9511	.3065	.3655	.9631	.3308	.3855	.9734	.3555
.3060	.9217	.2593	.3260	.9375	.2830	.3460	.9514	.3071	.3660	.9634	.3315	.3860	.9737	.3561
.3065	.9221	.2599	.3265	.9379	.2836	.3465	.9517	.3077	.3665	.9637	.3321	.3865	.9739	.3567
.3070	.9225	.2605	.3270	.9382	.2842	.3470	.9520	.3083	.3670	.9640	.3327	.3870	.9741	.3574
.3075	.9229	.2611	.3275	.9386	.2848	.3475	.9524	.3089	.3675	.9642	.3333	.3875	.9744	.3580
.3080	.9233	.2617	.3280	.9390	.2854	.3480	.9527	.3095	.3680	.9645	.3339	.3880	.9746	.3586
.3085	.9237	.2623	.3285	.9393	.2860	.3485	.9530	.3101	.3685	.9648	.3345	.3885	.9748	.3592
.3090	.9242	.2629	.3290	.9397	.2866	.3490	.9533	.3107	.3690	.9651	.3351	.3890	.9750	.3598
.3095	.9246	.2635	.3295	.9401	.2872	.3495	.9536	.3113	.3695	.9653	.3357	.3895	.9753	.3605
.3100	.9250	.2640	.3300	.9404	.2878	.3500	.9539	.3119	.3700	.9656	.3364	.3900	.9755	.3611
.3105	.9254	.2646	.3305	.9408	.2884	.3505	.9543	.3125	.3705	.9659	.3370	.3905	.9757	.3617
.3110	.9258	.2652	.3310	.9411	.2890	.3510	.9546	.3131	.3710	.9661	.3376	.3910	.9759	.3623
.3115	.9262	.2658	.3315	.9415	.2896	.3515	.9549	.3137	.3715	.9664	.3382	.3915	.9762	.3629
.3120	.9266	.2664	.3320	.9419	.2902	.3520	.9552	.3143	.3720	.9667	.3388	.3920	.9764	.3636
.3125	.9270	.2670	.3325	.9422	.2908	.3525	.9555	.3150	.3725	.9669	.3394	.3925	.9766	.3642
.3130	.9274	.2676	.3330	.9426	.2914	.3530	.9558	.3156	.3730	.9672	.3401	.3930	.9768	.3648
.3135	.9278	.2682	.3335	.9429	.2920	.3535	.9561	.3162	.3735	.9675	.3407	.3935	.9771	.3654
.3140	.9282	.2688	.3340	.9433	.2926	.3540	.9564	.3168	.3740	.9677	.3413	.3940	.9773	.3661
.3145	.9286	.2693	.3345	.9436	.2932	.3545	.9567	.3174	.3745	.9680	.3419	.3945	.9775	.3667
.3150	.9290	.2699	.3350	.9440	.2938	.3550	.9570	.3180	.3750	.9682	.3425	.3950	.9777	.3673
.3155	.9294	.2705	.3355	.9443	.2944	.3555	.9573	.3186	.3755	.9685	.3431	.3955	.9779	.3679
.3160	.9298	.2711	.3360	.9447	.2950	.3560	.9576	.3192	.3760	.9688	.3438	.3960	.9781	.3685
.3165	.9302	.2717	.3365	.9450	.2956	.3565	.9579	.3198	.3765	.9690	.3444	.3965	.9783	.3692
.3170	.9306	.2723	.3370	.9454	.2962	.3570	.9582	.3204	.3770	.9693	.3450	.3970	.9786	.3698
.3175	.9310	.2729	.3375	.9457	.2968	.3575	.9585	.3211	.3775	.9695	.3456	.3975	.9788	.3704
.3180	.9314	.2735	.3380	.9461	.2974	.3580	.9588	.3217	.3780	.9698	.3462	.3980	.9790	.3710
.3185	.9318	.2741	.3385	.9464	.2980	.3585	.9591	.3223	.3785	.9700	.3468	.3985	.9792	.3717
.3190	.9322	.2747	.3390	.9467	.2986	.3590	.9594	.3229	.3790	.9703	.3475	.3990	.9794	.3723
.3195	.9326	.2753	.3395	.9471	.2992	.3595	.9597	.3235	.3795	.9705	.3481	.3995	.9796	.3729
.4000	.9798	.3735	.4200	.9871	.3986	.4400	.9928	.4238	.4600	.9968	.4491	.4800	.9992	.4745
.4005	.9800	.3742	.4205	.9873	.3992	.4405	.9929	.4244	.4605	.9969	.4498	.4805	.9992	.4752
.4010	.9802	.3748	.4210	.9874	.3998	.4410	.9930	.4251	.4610	.9970	.4504	.4810	.9993	.4758
.4015	.9804	.3754	.4215	.9876	.4005	.4415	.9931	.4257	.4615	.9970	.4510	.4815	.9993	.4765
.4020	.9806	.3760	.4220	.9878	.4011	.4420	.9932	.4263	.4620	.9971	.4517	.4820	.9994	.4771
.4025	.9808	.3767	.4225	.9879	.4017	.4425	.9934	.4270	.4625	.9972	.4523	.4825	.9994	.4777
.4030	.9810	.3773	.4230	.9881	.4023	.4430	.9935	.4276	.4630	.9973	.4529	.4830	.9994	.4784
.4035	.9812	.3779	.4235	.9882	.4030	.4435	.9936	.4282	.4635	.9973	.4536	.4835	.9995	.4790
.4040	.9814	.3785	.4240	.9884	.4036	.4440	.9937	.4288	.4640	.9974	.4542	.4840	.9995	.4796
.4045	.9816	.3791	.4245	.9885	.4042	.4445	.9938	.4295	.4645	.9975	.4548	.4845	.9995	.4803
.4050	.9818	.3798	.4250	.9887	.4049	.4450	.9939	.4301	.4650	.9975	.4555	.4850	.9995	.4809
.4055	.9820	.3804	.4255	.9888	.4055	.4455	.9940	.4307	.4655	.9976	.4561	.4855	.9996	.4815
.4060	.9822	.3810	.4260	.9890	.4061	.4460	.9942	.4314	.4660	.9977	.4567	.4860	.9996	.4822
.4065	.9824	.3816	.4265	.9891	.4068	.4465	.9943	.4320	.4665	.9978	.4574	.4865	.9996	.4828
.4070	.9825	.3823	.4270	.9893	.4074	.4470	.9944	.4326	.4670	.9978	.4580	.4870	.9997	.4834
.4075	.9827	.3829	.4275	.9894	.4080	.4475	.9945	.4333	.4675	.9979	.4586	.4875	.9997	.4841
.4080	.9829	.3835	.4280	.9896	.4086	.4480	.9946	.4339	.4680	.9979	.4593	.4880	.9997	.4847
.4085	.9831	.3842	.4285	.9897	.4093	.4485	.9947	.4345	.4685	.9980	.4599	.4885	.9997	.4854
.4090	.9833	.3848	.4290	.9899	.4099	.4490	.9948	.4352	.4690	.9981	.4606	.4890	.9998	.4860
.4095	.9835	.3854	.4295	.9900	.4105	.4495	.9949	.4358	.4695	.9981	.4612	.4895	.9998	.4866
.4100	.9837	.3860	.4300	.9902	.4112	.4500	.9950	.4364	.4700	.9982	.4618	.4900	.9998	.4873
.4105	.9838	.3867	.4305	.9903	.4118	.4505	.9951	.4371	.4705	.9983	.4625	.4905	.9998	.4879
.4110	.9840	.3873	.4310	.9904	.4124	.4510	.9952	.4377	.4710	.9983	.4631	.4910	.9998	.4885
.4115	.9842	.3879	.4315	.9906	.4131	.4515	.9953	.4383	.4715	.9984	.4637	.4915	.9999	.4892
.4120	.9844	.3885	.4320	.9907	.4137	.4520	.9954	.4390	.4720	.9984	.4644	.4920	.9999	.4898
.4125	.9846	.3892	.4325	.9908	.4143	.4525	.9955	.4396	.4725	.9985	.4650	.4925	.9999	.4905
.4130	.9847	.3898	.4330	.9910	.4149	.4530	.9956	.4402	.4730	.9985	.4656	.4930	.9999	.4911
.4135	.9849	.3904	.4335	.9911	.4156	.4535	.9957	.4409	.4735	.9986	.4663	.4935	.9999	.4917
.4140	.9851	.3910	.4340	.9912	.4162	.4540	.9958	.4415	.4740	.9986	.4669	.4940	.9999	.4924
.4145	.9853	.3917	.4345	.9914	.4168	.4545	.9959	.4421	.4745	.9987	.4675	.4945	.9999	.4930
.4150	.9854	.3923	.4350	.9915	.4175	.4550	.9959	.4428	.4750	.9987	.4682	.4950	1.0000	.4936
.4155	.9856	.3929	.4355	.9916	.4181	.4555	.9960	.4434	.4755	.9988	.4688	.4955	1.0000	.4943
.4160	.9858	.3936	.4360	.9918	.4187	.4560	.9961	.4440	.4760	.9988	.4695	.4960	1.0000	.4949
.4165	.9860	.3942	.4365	.9919	.4194	.4565	.9962	.4447	.4765	.9989	.4701	.4965	1.0000	.4955
.4170	.9861	.3948	.4370	.9920	.4200	.4570	.9963	.4453	.4770	.9989	.4707	.4970	1.0000	.4962
.4175	.9863	.3954	.4375	.9922	.4206	.4575	.9964	.4460	.4775	.9990	.4714	.4975	1.0000	.4968
.4180	.9865	.3961	.4380	.9923	.4213	.4580	.9965	.4466	.4780	.9990	.4720	.4980	1.0000	.4975
.4185	.9866	.3967	.4385	.9924	.4219	.4585	.9965	.4472	.4785	.9991	.4726	.4985	1.0000	.4981
.4190	.9868	.3973	.4390	.9925	.4225	.4590	.9966	.4479	.4790	.9991	.4733	.4990	1.0000	.4987
.4195	.9870	.3979	.4395	.9927	.4232	.4595	.9967	.4485	.4795	.9992	.4739	.4995	1.0000	.4994
												.5000	1.0000	.5000

Percent of Flood at Constant V/L Ratio

With various areas established, the “percent of flood,” i.e., design Vload expressed as a percent of the flood Vload, may be calculated by Equation 13.

$$\frac{\% \text{ Flood}}{100} = \frac{\text{Vload} + \text{GPM} \times \text{FPL}/13000}{\text{AA} \times \text{CAF}} \quad (13)$$

NOTE: Equations (14), (15), and (16) are omitted from this edition since they no longer have valid application.

The capacity of Ballast trays is also a function of the dry tray pressure drop. Columns with a short flow path length, small diameter columns, or columns with obstructions in the active area will have fewer Ballast units per square foot of active area than do columns not having these limitations. The number of Ballast units used on a tray may also be reduced from the maximum potential number to obtain a minimum cost design or for process reasons, i.e., to obtain efficient operation at substantially reduced rates. The following equation covers this criterion:

$$\left[\Delta P_{\text{dry}} \right]_{\text{flood}} = \text{TS} \times .2 \quad (17)$$

where TS = tray spacing, inches

ΔP_{dry} = dry tray pressure drop from page 27 based on V-I units

Flood Vload

The flood Vload at constant vapor to liquid ratio is the design (Vload) (100) divided by the percent of flood.

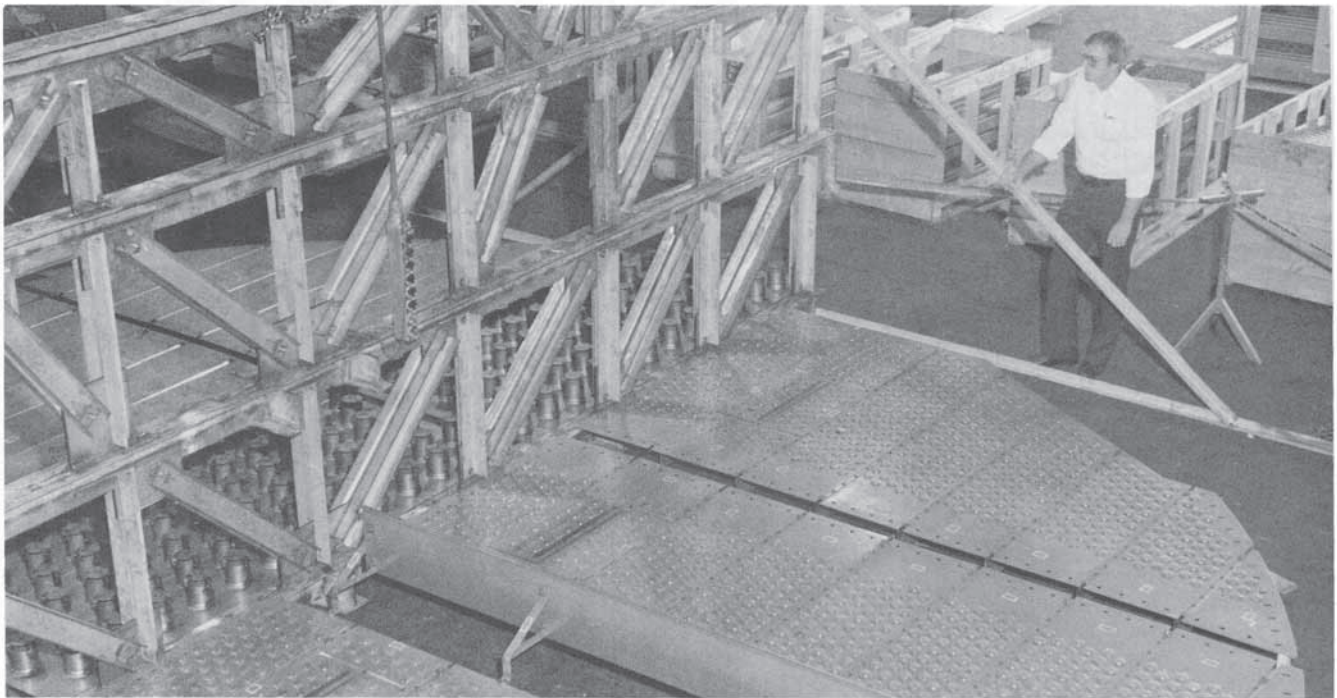

Major beams (lattice type) supporting four levels of trays.

Pressure Drop

The pressure drop of Ballast trays is a function of vapor and liquid rates; number, type, metal density, and thickness of the valve; weir height and weir length. At low to moderate vapor rates, when the valves are not all fully open, the dry tray pressure drop is proportional to the valve weight and is essentially independent of the vapor rate. At vapor rates sufficiently high to open the valves fully, the dry tray pressure drop is proportional to the square of the vapor velocity through the orifices.

Dry Tray Pressure Drop. The dry tray pressure drop of the V-1 and V-4 Ballast trays most frequently used is obtained from Figure 8. This nomogram is based on a valve metal density of 510 lb cu ft.

The following two equations may be used for conditions not covered by the nomogram. The larger value is correct.

$$\text{units part open: } \Delta P_{\text{dry}} = 1.35t_m D_m / D_L + K_1 (V_H)^2 D_V / D_L \quad (18a)$$

$$\text{units full open: } \Delta P_{\text{dry}} = K_2 (V_H)^2 D_V / D_L \quad (18b)$$

where ΔP_{dry} = inches liquid
 t_m = valve thickness, inches
 D_m = valve metal density, lb/cu ft
 K_1, K_2 = pressure drop coefficients
 V_H = hole velocity, ft/sec

Values of K_1 and K_2 are given below together with the thickness corresponding to several gages and densities of commonly used metals.

PRESSURE DROP COEFFICIENTS

Type Unit	K_1	K_2 for deck thickness of				
		.074"	.104"	.134"	0.187"	0.250"
V-1	.20	1.18	.95	.86	.67	.61
V-4	.10	.68	.68	.68	n.a.	n.a.

Thickness		Valve Material			
Gage	t_m , inches	Metal	Density lb/cu ft	Metal	Density lb/cu ft
20	.037	C.S.	490	Hastelloy	560
18	.050	S.S.	500	Aluminum	168
16	.060	Nickel	553	Copper	560
14	.074	Monel	550	Lead	708
12	.104	Titanium	283		
10	.134				

Hole Area. The area used to calculate hole velocity in Equation 18 is as follows:

$$A_H = NU/78.5 \quad (19)$$

where NU = total number of Ballast units

A_H = hole area, sq ft

See page 31 for an estimate of the number of units.

Total Tray Pressure Drop, ΔP . Total tray pressure drop is calculated from the following equation:

$$\Delta P = \Delta P_{\text{tray}} + .4(\text{gpm}/L_{wi})^{2/3} + .4 H_w \quad (20)$$

where ΔP = total pressure drop, inches liquid
 H_w = weir height, inches
 L_{wi} = weir length, inches

Pressure drop in inches of liquid can be converted to pounds per square inch or mm Hg by the following equations:

$$\Delta P, \text{ lb/sq in} = (\Delta P, \text{ inch liq})(D_L)/1728 \quad (21a)$$

$$\Delta P, \text{ mm Hg} = (\Delta P, \text{ inch liq})(D_L)/33.3 \quad (21b)$$

Downcomer Backup

The downcomer backup should not exceed 40% of the tray spacing for high vapor density systems (approximately 3.0 lbs/cu.ft.), 50% for medium vapor densities and 60% for vapor densities under 1.0 lbs/cu. ft. Otherwise, flooding may occur prior to the rate calculated by the jet flood equations. Downcomer backup, H_{dc} , in inches of liquid is calculated as follows:

$$H_{dc} = H_w + .4 (\text{gpm}/L_{wi})^{2/3} + [\Delta P_{\text{tray}} + H_{ud}] \left[\frac{D_L}{D_L - D_v} \right] \quad (22)$$

$$H_{ud} = .65 (V_{ud})^2 \quad \text{or} = 0.06 \left(\frac{\text{gpm}/\text{DCE}}{\text{DCCL}} \right)^2 \quad (23)$$

where H_{ud} = head loss under downcomer, inches liquid
 V_{ud} = liquid velocity under downcomer, ft/sec
 H_{dc} = liquid height in downcomer, inches
DCCL = downcomer clearance, inches
DCE = length of downcomer exit, inches

Flexibility

The estimated vapor velocity at which no leakage occurs on a single-pass conventional valve type tray is expressed by the following $V_{HV}/\sqrt{D_v/D_L}$ values versus the liquid level on the tray:

Liquid Level	1	1.5	2.0	2.5	3.0	3.5	4.0
V-1	0.35	0.45	0.53	0.59	0.69	0.75	0.82
V-4	0.63	0.81	0.97	1.11	1.24	1.36	1.48

The above velocities represent the leakage point with a standard design and can be reduced or increased by the choice of Glitsch Ballast units used. These are for guidance only, since a leakage rate of 25% of the liquid on the tray normally represents a 10 per cent loss in efficiency.

If adequate flexibility cannot be obtained when using the maximum complement of units, either of several methods may be taken to extend the lower operating limit to any desired value within reason: (1) increase the cap spacing to reduce the number of units or omit rows of units at the inlet or outlet edge of the tray; (2) use heavy units with a zero tab height (zero initial opening) at selected rows, if pressure drop permits. These units are considered as inactive. A-1 or V-2 units may be used for very low liquid rates or where complete closure is desired.

$V_H^2 D_V/D_L$

ΔP_D " LIQUID

FIGURE 8
BALLAST TRAYS
DRY TRAY ΔP_D
V-1 & V-4 TRAYS

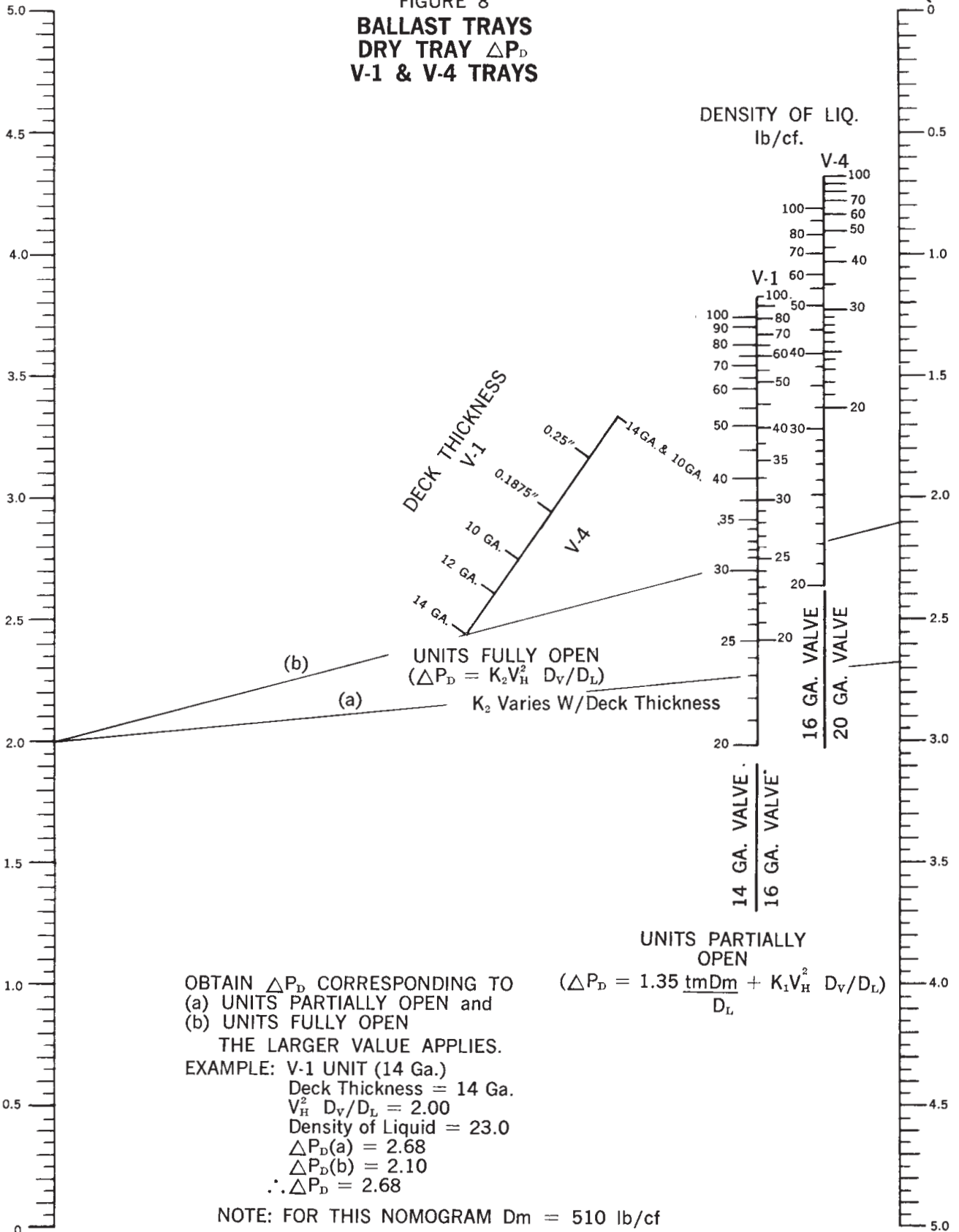

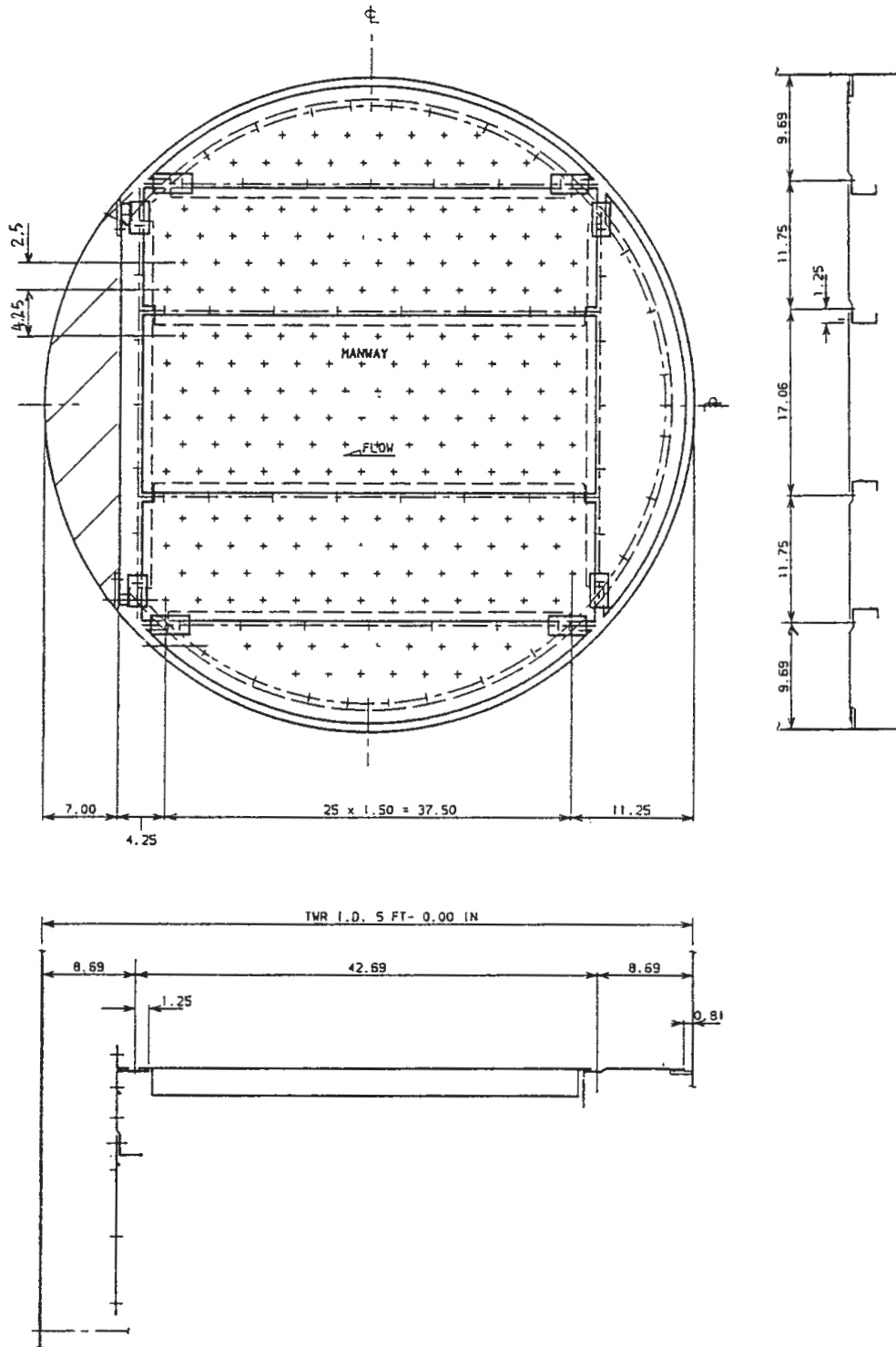

FIGURE 9
 TYPICAL 5'-0" SINGLE PASS BALLAST TRAY

Flow Path Width, WFP

The width of flow path is defined as the active area in square inches divided by the flow path length. This term is used to estimate the number of Ballast units.

$$\text{WFP} = \text{AA} \times 144/\text{FPL} \quad (26)$$

Approximate Number of Ballast Units

The number of Ballast units which will fit within the active area is the number of rows of units multiplied by the average number of units per row, with corrections for tray manway loss. This can be estimated as follows:

1. With truss lines parallel to liquid flow,

$$\text{Rows} = \left[\frac{\text{FPL} - 8.5}{.5 \times \text{Base}} + 1 \right] \left[\text{NP} \right] \quad (27)$$

$$\text{Units/Row} = \frac{\text{WFP}}{5.75 \times \text{NP}} - (.8)(\text{No. Major Beams} + 1) \quad (28)$$

2. With truss lines perpendicular to liquid flow,

$$\text{Rows} = \left[\frac{\text{FPL} - 1.75 \times \text{No. Trusses} - 6.0}{2.5} \right] \left[\text{NP} \right] \quad (29)$$

$$\text{Units/Row} = \frac{\text{WFP}}{\text{Base} \times \text{NP}} - (2)(\text{No. Major Beams} + 1) \quad (30)$$

where FPL = Flow path length, inches

WFP = Width of flow path, inches

NP = Number of passes

Base = Base spacing of units, usually 3.0, 3.5, 4.0, 4.5 or 6.0 inches

There will be approximately 12 to 14 units per square foot of active area using a base of 3 inches. Fewer units can be obtained by omitting rows or changing the base to use one of the other standard dimensions.

Truss lines are usually parallel to liquid flow in columns not having a major beam, but are usually perpendicular to liquid flow in columns having a major beam. Swept-back weirs will result in a loss of Ballast units. The actual number of Ballast units used on a tray can be determined only by a detailed tray layout.

A typical tray layout is shown on Figure 9.

FIGURE 10

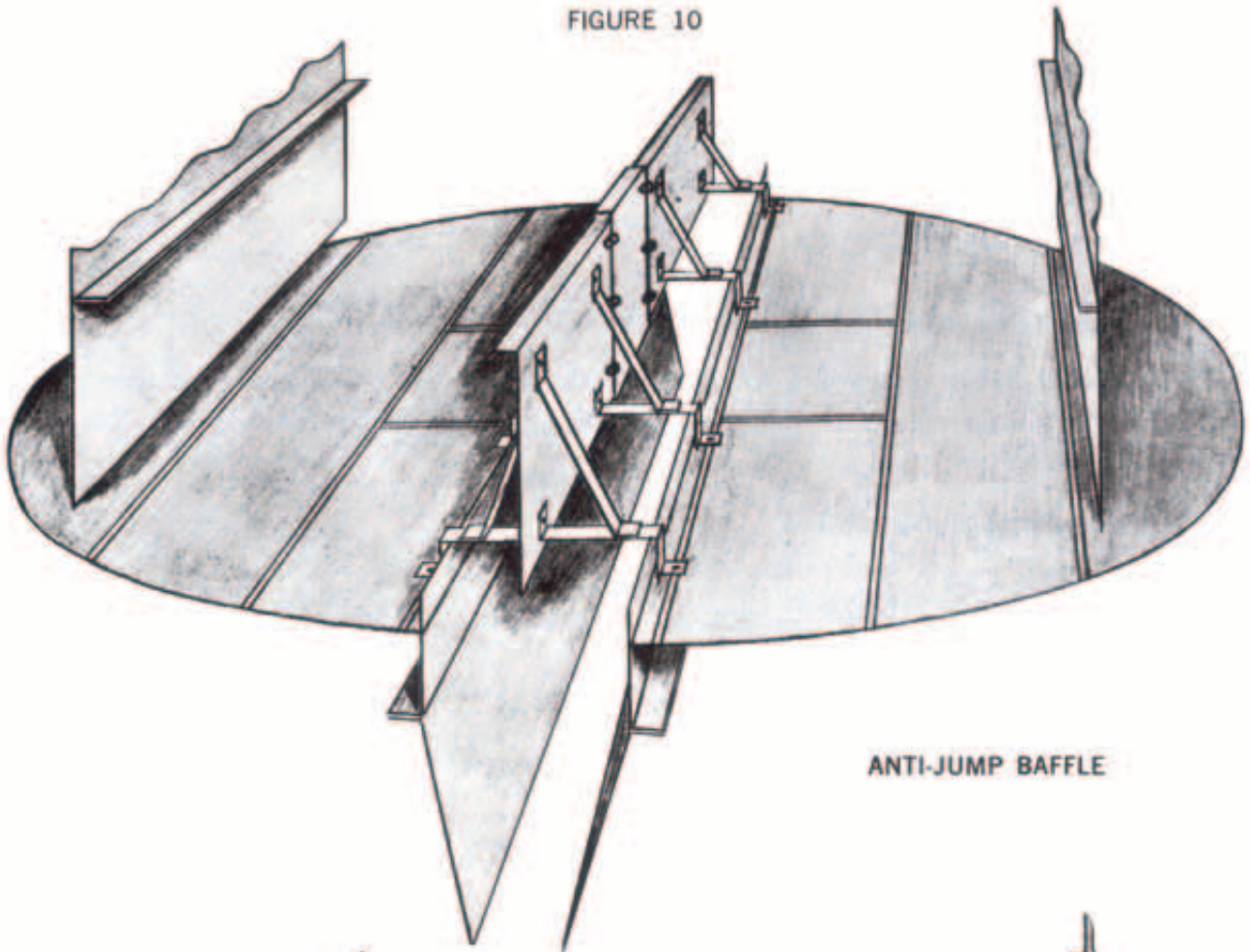

ANTI-JUMP BAFFLE

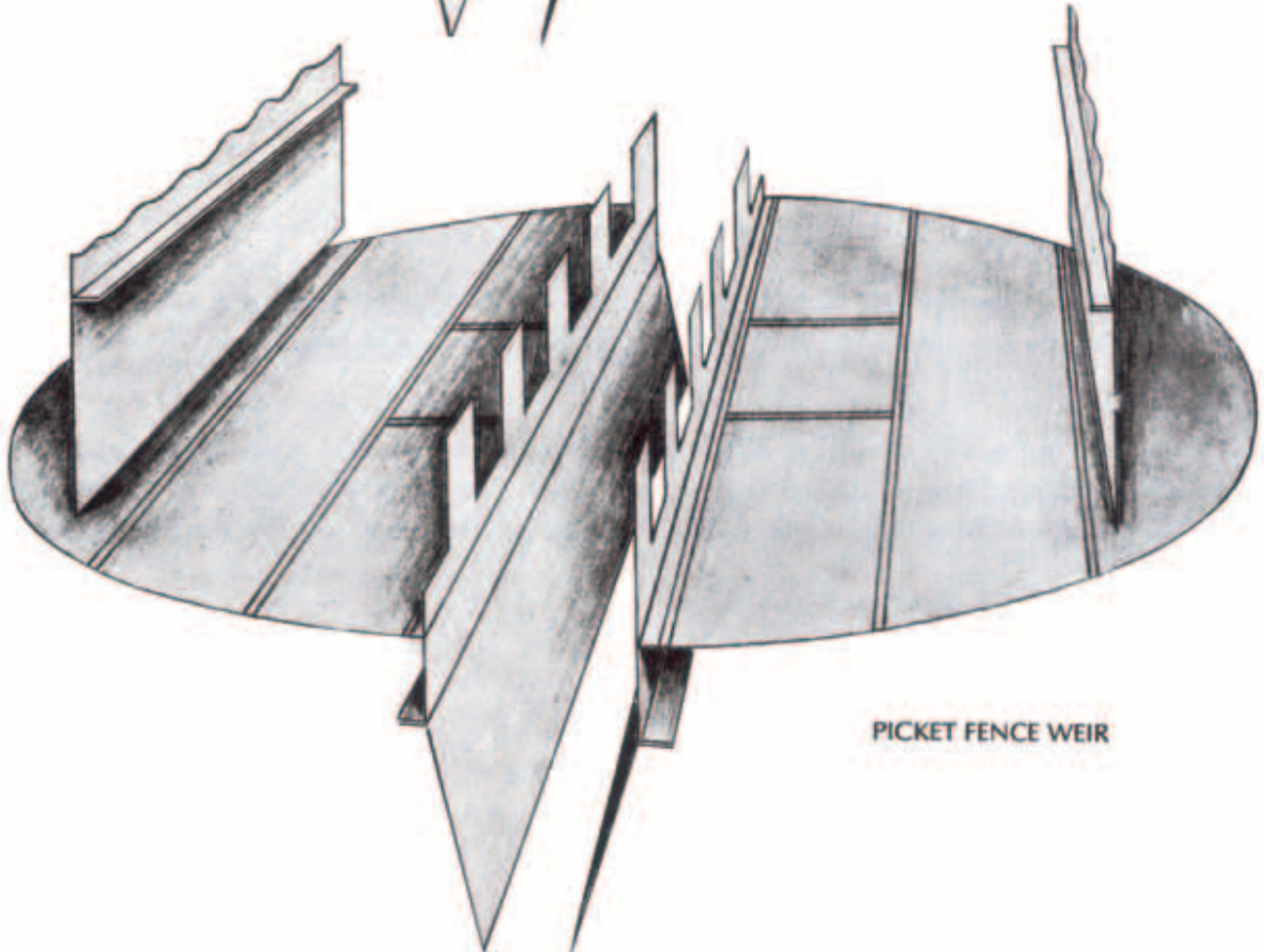

PICKET FENCE WEIR

Anti-Jump Baffles for Multipass Trays

Operation at high rates require that anti-jump baffles be added at the center and/or off-center downcomers of multipass trays. A discussion of the function, conditions which require such baffles, and mechanical design follows. These comments apply to all types of trays; bubble cap, sieve, etc.

Anti-jump baffles consist of a metal plate suspended vertically above the center and off-center downcomers of multipass trays. The bottom of the baffle is normally at the same elevation as the top of the overflow weir. The top of the baffle is 11" to 20" above the tray floor. The baffle is essentially equal in length to the weir length but does not require sealing at joints or the tower shell. It is normally made in three pieces; the center piece being a manway.

These baffles have been tested thoroughly in a three foot wide x six foot long air-water simulator and are in successful service in over 2000 columns. By observation, vapor expansion at the outlet weir pumps the liquid over the weir. At a sufficiently high vapor rate, the trajectory carries the liquid completely over the downcomer and onto the opposite side of the tray. The tray then floods prematurely due to increased liquid holdup, caused by cycling of the liquid across one side of the tray and back to the other. Anti-jump baffles deflect the liquid into the downcomer, as does the tower shell when the flow is towards the side downcomers. Baffles are recommended if the operating V_{load}/AA exceeds the limiting V_{load}/AA :

$$\text{where limiting } V_{load}/AA = 0.336 - 0.0192 \text{ (GPM/WFP)}$$

There are other factors which could cause baffles to be required.

Picket Fence Weirs

Picket Fence Weirs are normally recommended if the GPM/L_{wi} is less than 0.25-0.30. These are shown on the opposite page. For very low liquid rates splash baffles are recommended. These are solid plates extending from shell to shell. The solid baffle is parallel to, and located just before, the overflow weir.

Number of Passes

Usually, a smaller tower diameter can be obtained by using multipass trays to hold liquid rates below 8 GPM/WFP. The number of Ballast units which can be placed on a tray decreases as the number of passes increases; and, both pressure drop and downcomer backup may increase. Tray efficiency will decrease with increasing number of passes due to the smaller flow path length. The minimum practical diameter and preferred diameter for multipass trays is shown below.

<u>No. Passes</u>	<u>Minimum Diameter, Ft.</u>	<u>Preferred Diameter, Ft.</u>
Two	5	6
Three	8	9
Four	10	12
Five	13	15

Many customers prefer to use trays having no more than two passes. If the number of passes is restricted, either by customer preference or by tower diameter limitations, liquid rates up to 20 GPM/WFP can be and have been used.

FIGURE 11 Downcomer Types

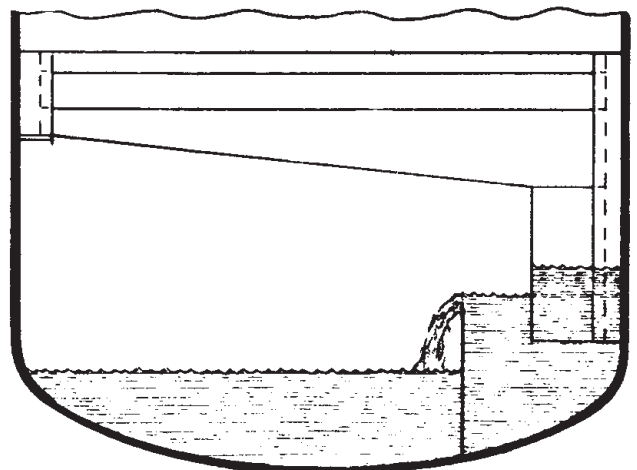
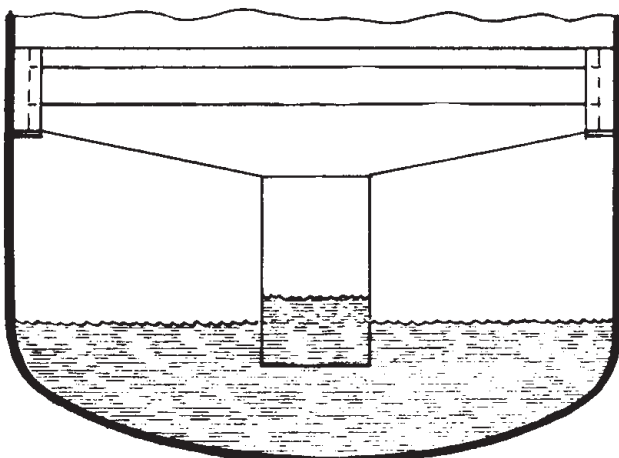
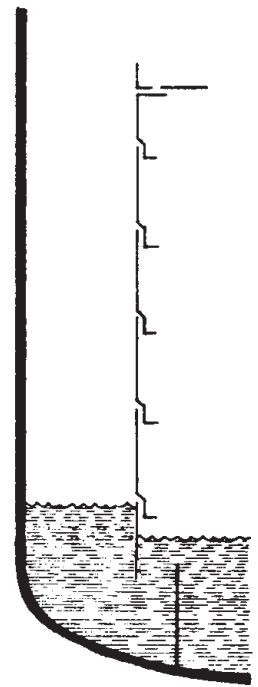
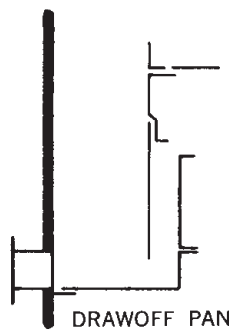
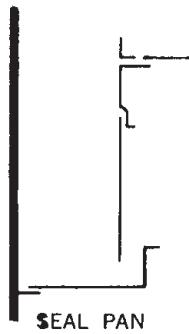
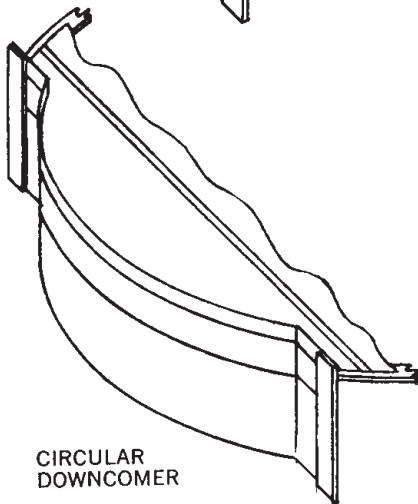
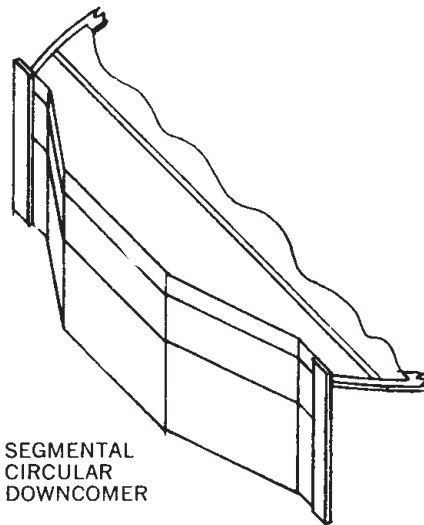
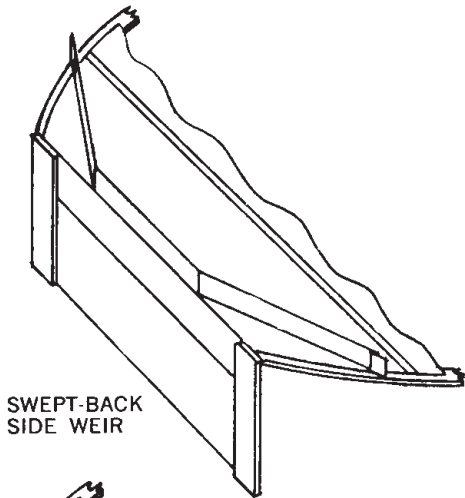
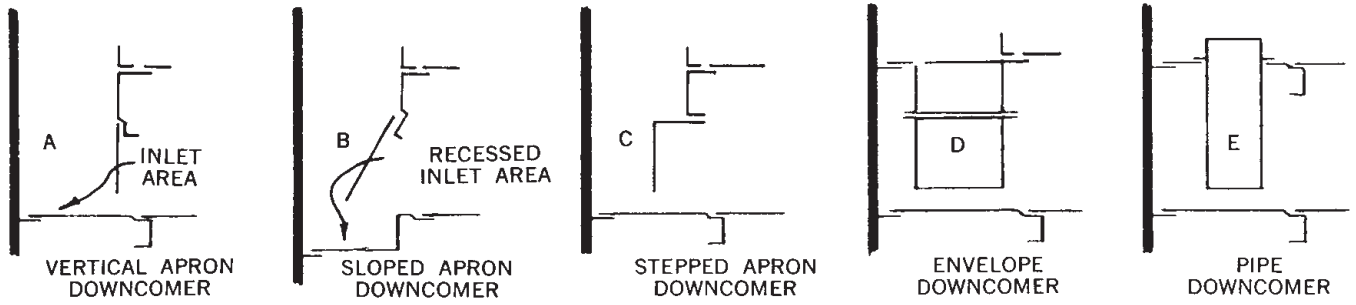

Weir Length

Weir lengths may be obtained from Table 4. An average weir length for even-numbered and odd-numbered trays of two and four pass trays is used for calculating pressure drop. A swept-back weir on the side downcomers can be used to increase the weir length for purposes of reducing pressure drop. A swept-back weir does not significantly change either the active area or the effective downcomer area, or the capacity of the trays.

Weir Height

A weir height of 2" is used in most services. Exceptions are those having a low pressure drop specification. A weir height as low as 1/2" has been used in vacuum columns but a 3/4" minimum weir height is normally recommended. A weir height up to 6" can be used where a high liquid residence time is necessary, for example where a chemical reaction is involved. If the weir height is greater than 15% of the tray spacing, the effective tray spacing for purposes of calculating percent of flood should be reduced by the excess of the weir height over 15% of the tray spacing.

Inlet Weirs

Inlet weirs ordinarily are not used with Ballast trays except to distribute reflux to the top tray or to insure a positive seal at high vapor rates and low liquid rates.

Inlet Sumps

Recessed inlet sumps used in conjunction with sloped or stepped downcomers have the following advantages as a method for introducing liquid to the tray.

1. A positive seal is provided under all operating conditions.
2. Liquid enters the tray with a vertical component rather than with only a horizontal movement. This results in better aeration at the inlet edge of the tray and increases both tray efficiency and capacity.
3. Decreases downcomer backup.

Inlet sumps are slightly more expensive than flat seal areas. However, the added cost is small compared with value received.

Area Under Downcomer, AUD

The term AUD is used to designate the most restricted area at the bottom of the downcomer. This area is usually established at 1/2 to 1/3 that at the top of the downcomer. A velocity of 1.5'/sec is not unusual. Foamy systems require a lower velocity.

Downcomer Types

Various types of downcomers are shown on Figure 11.

Example Design Problem

A two pass tray design with a 20 inch tray spacing will be illustrated. Design loads together with a summary of design calculations are shown on the facing page. The method of determining the proper downcomer area for maximum capacity is shown below. The column will be designed for not more than 70% of flood by customer specification; i.e., the flood factor is .70. The system is nonfoaming, and the system factor is 1.0.

$$\text{Eq. 1c } VD_{\text{avg}} = 7.5 \times \sqrt{20} \times \sqrt{29.33 - 2.75} \times 1.0 = 170 \text{ gpm/sq ft}$$

$$\text{Eq. 2a } CAF = .395 \times 1.0 = .395 \text{ ft/sec}$$

$$\text{Fig. 6 } \text{Approximate DT} = 7'-6'' \text{ (based on 24'' TS \& 80\% Flood)}$$

$$\text{Eq. 3 } \text{Approximate FPL} = 9 \times 7.5/2 = 33.7 \text{ inches}$$

$$\text{Eq. 4 } AAM = (8.86 + 1100 \times 33.7/13000)/(.395 \times .70) = 42.5 \text{ sq ft}$$

$$\text{Eq. 5 } ADM = 1100/(170 \times .70) = 9.25 \text{ sq ft}$$

$$\text{Eq. 6b } ATM = 42.5 + 2 \times 9.25 = 61.0 \text{ sq ft}$$

$$\text{Eq. 7 } DT = \sqrt{61.0/7854} = 8.8 \text{ ft. Use 9'-0'' or 108''}$$

$$AT = .785 \times 9.0^2 = 63.62 \text{ sq ft}$$

$$\text{Eq. 8 } AD = 63.62 \times 9.25/61.0 = 9.9 \text{ sq ft}$$

AD is more than 10% of column area. OK

$$\text{Eq. 9 } H_3 = 12 \times 9.9/9.0 = 13.2 \text{ inches}$$

$$AD_1 = 9.9/2 = 4.95$$

$$AD_1/AT = 4.95/63.62 = .0777$$

$$H_1/D = .1315 \text{ from Table 4}$$

$$H_1 = .1315 \times 108 = 14.2 \text{ inches}$$

$$\text{Eq. 10 } FPL = (12 \times 9 - (2 \times 14.2 + 13.2))/2 = 33.2 \text{ inches}$$

$$\text{Modular FPL} = 32.5 \text{ or } 34 \text{ inches, use } 32.5$$

$$\text{Use } H_1 = 14.5, H_3 = 14''$$

$$AD_1 = 5.09 \text{ sq ft each} \quad 2 \times AD_1 = 10.18$$

$$AD_3 = 10.5 \text{ sq ft} \quad \text{Average AD} = 10.34 \text{ sq ft}$$

$$\text{Eq. 12a } AA = 63.62 - 20.68 = 42.94 \text{ sq ft}$$

$$\text{Eq. 13 } \% \text{ Flood} = \frac{(100)(8.86 + 1100 \times 32.5/13000)}{42.94 \times .395} = 68.6$$

$$\text{Eq. 14 } \% \text{ Flood} = \frac{100(8.86)}{63.62 \times .395 \times .78} = 45.2$$

Since Eq. 13 gives greater value than Eq. 14, use Eq. 13

Ballast Tray Design

Customer _____ Inq. No. _____
 User _____

Glitsch Job No. _____ Date _____
 Sheet _____ of _____ Rev. _____

Vessel No. E-3 Service C3 Splitter
 DT, Tower Dia. 9'-0" = 108 inches
 AT, Tower Area 63.62 sq ft
 AA, Active Area 42.94 sq ft
 AD, Downcomer Area 10.34 sq ft
 NP, No. of flow paths 2
 FPL, flow path length 32.5 inches
 WFP, flow path width 190 inches
 L_{wi}, weir length: 181.7 inch; swept NO
 H_w, weir height: 2 inch; adj. NO
 Anti-jump baffles on trays future loads
 Draw pans on trays _____
 Feed to trays _____; vaporized _____
 Manholes on trays _____ I.D. _____
 Mtl/Thk: Valve 410ss/16Ga.; Decks C5/10Ga.
 Packing: Tray Sumps Truss Ends None

Downcomer Dimensions	D.C. Width inches	Weir Length inches	Area sq ft each
Side	<u>14.5</u>	<u>73.7</u>	<u>5.09</u>
Center	<u>14.0</u>	<u>216.0</u>	<u>10.5</u>
Off-ctr			
Off-side			
Σ Typ. even	<u>29.0</u>	<u>147.4</u>	<u>10.18</u>
Σ Typ. odd	<u>14.0</u>	<u>216.0</u>	<u>10.5</u>
Total	<u>43.0</u>	<u>363.4</u>	<u>20.68</u>
Average		<u>181.7</u>	<u>10.34</u>
Residence Time	_____ sec		
D.C. Area, % of AT	<u>17.65</u>		
D.C. Type	<u>B</u>	Clearance	<u>4"</u>
Btm D.C.:	seal pans <input type="checkbox"/> ; extended <input type="checkbox"/> total draw <input type="checkbox"/> ; boxed <input type="checkbox"/>		

Loadings at Tray No.		<u>1</u>								
No. Trays in Section		<u>75</u>								
Tray Spacing, inches		<u>20</u>								
System (foam) Factor		<u>1.0</u>								
Vapor	Rate, lbs/hr	<u>271,500</u>								
	Rate, cfs, cu ft/sec	<u>27.52</u>								
	D _v , lb/cu ft	<u>2.75</u>								
	Vload, cfs/√D _v /(D _L - D _v)	<u>8.86</u>								
CAF		<u>.395</u>								
Liquid	Rate, lb/hr	<u>259,100</u>								
	Rate, GPM	<u>1100</u>								
	D _L , lb/cu ft	<u>29.33</u>								
	VD _{dsg}	<u>170</u>								
(AD × VD _{dsg} /GPM) ⁻⁶ = DLF		<u>1.326</u>								
% Flood, const. V/L, Eq. 13		<u>68.6</u>								
Pressure Drop	Valve Type	Thk. inch	<u>V-1</u>	<u>.06</u>						
	No. Valves	A _n , sq ft	<u>534</u>	<u>6.8</u>						
	V _h ² D _v /D _L	ΔP _{dry}	<u>1.55</u>	<u>1.75</u>						
	GPM/L _{wi}	H _{ow}	<u>6.05</u>	<u>1.33</u>						
	H _w , inches	.4 × H _w	<u>2.0</u>	<u>.80</u>						
	ΔP, inches liquid		<u>3.88</u>							
	ΔP, mm Hg or psi									
	Vload/A _n	dsgn	min	<u>1.3</u>	<u>.73</u>					
A _{ud} , sq ft		<u>4.0</u>								
H _{ud} , inches liquid		<u>.25</u>								
H _{dc} , inches liquid		<u>7.88</u>								
Remarks _____										

Tray Efficiency

Figure 12 shows a plot of overall tray efficiency of the V-1 Ballast tray obtained in a 4'-0" diameter fractionating column on the isobutane/n-butane and cyclohexane/n-heptane systems at several pressures. The results of these tests are described fully in *Glitsch Bulletin No. 160*.

This figure may be used as a guide in selecting tray efficiency for design of commercial columns for similar systems. However, the usual practice has been to establish the number of trays required to obtain the desired separation with bubble cap or sieve trays and to use the same number of Ballast trays. The V-4 Ballast tray has been used to separate the ethylbenzene-styrene system in a single column without having an excessive bottom tray pressure.

Large size V-2 Ballast units have been used to replace bubble cap and riser assemblies in existing columns. The efficiency and capacity of the installations have exceeded that of the original bubble cap tray.

Extra trays to compensate for mislocation of the feed tray and instrumentation swings should be considered when the number of trays is established.

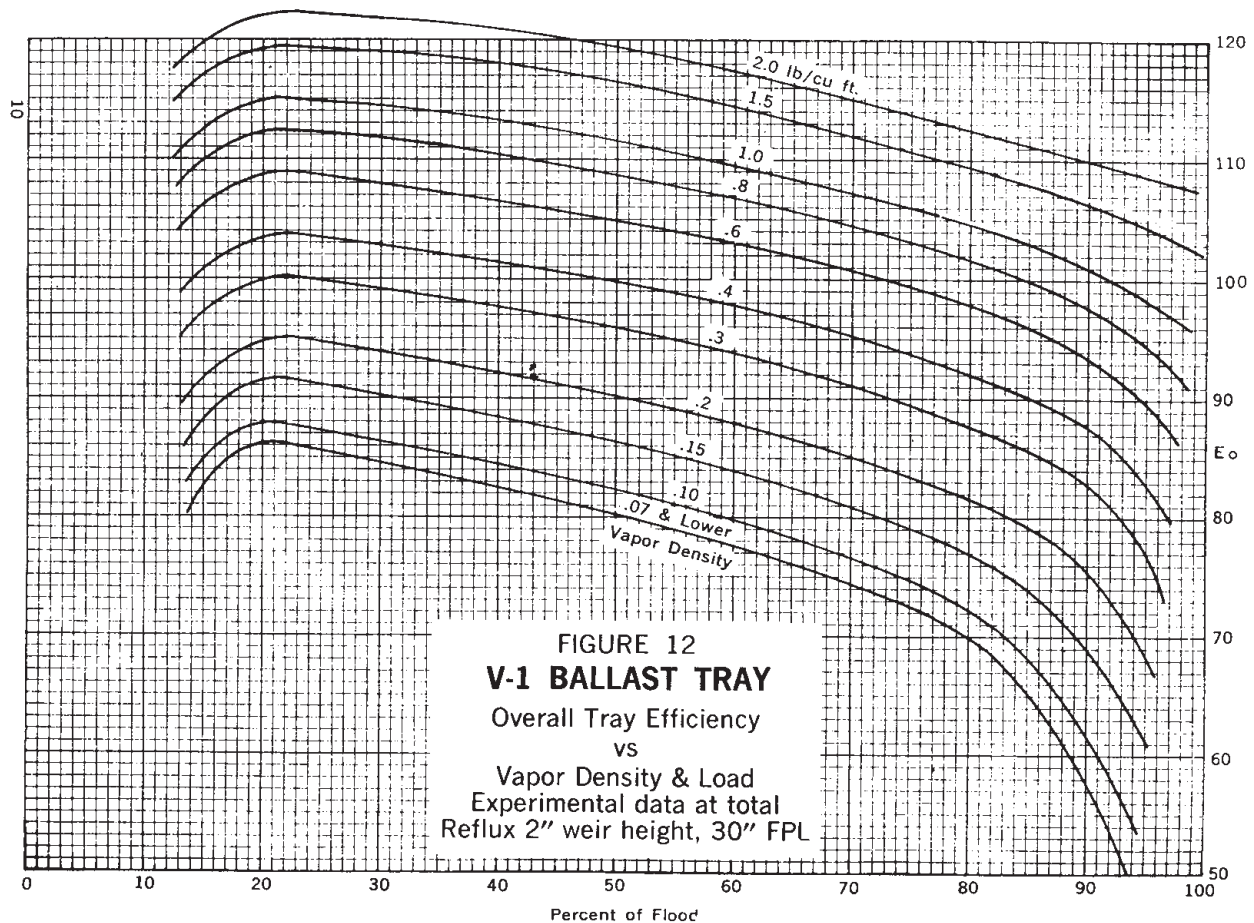

Mechanical Details

Ballast Unit Spacing

Orifices of $1\frac{17}{32}$ " diameter are punched in the deck for insertion of Ballast units. A group of up to seven holes may be punched on each stroke of the press when the standard close pitch is used. Four of the holes are in one row and the other three are in another row which is displaced forward $1\frac{1}{2}$ " and staggered midway between the holes of the adjacent line. The deck panel progresses 3" with each stroke and produces a pattern of holes having a triangular base of 3" and a height of 2.5". Truss lines are parallel to the base of the triangle.

The base of the triangle can be changed at will. Standard triangular base dimensions of $3\frac{1}{2}$, 4, $4\frac{1}{2}$ and 6 inches in addition to the 3" base are used. The triangular height of 2.5" is used for all spacings; this permits modular deck panel widths to be used.

Weir to Ballast Unit Distance

The distance from the outlet weir to the centerline of the nearest row of Ballast units is standardized at $4\frac{1}{4}$ ". The distance from the inlet edge of the tray to the nearest Ballast unit is also $4\frac{1}{4}$ ". These dimensions are varied for special applications.

Tower Manhole Size (Inside Diameter)

The tower manhole inside diameter is a major factor in designing the trays, as this affects the tray manway width and the number of pieces that must be installed. Small tower manholes do not permit an optimum design and could appreciably affect the cost of the trays.

The number of rows of Ballast units on a panel and the depth of truss required for the mechanical design determine the minimum diameter of the vessel manhole required. If the number of rows of Ballast units per panel is 5, 6 or 7 (using $2\frac{1}{2}$ " row centers), the approximate manhole inside diameter required is 16", $18\frac{1}{2}$ " and 21", respectively. Large manholes are especially important for larger towers, or where a large number of trays is involved, as a reduction in the number of pieces becomes more significant.

Trusses

In small towers, the trusses usually run parallel to liquid flow. In towers requiring a major support beam, trusses usually run perpendicular to liquid flow. One or more major support beams are usually required for diameters greater than 12 ft. The major support beams are nearly always installed parallel to liquid flow.

The truss depth and construction is made adequate to support the tray weight plus 20 to 25 pounds per sq. ft. uniform load with a $\frac{1}{8}$ " maximum deflection for towers up to 12'-6" diameter. A $\frac{3}{16}$ " maximum deflection is usually allowed for towers above 12'-6" diameter. On very large diameter towers, the allowable deflection may be greater. The trusses can be cambered to compensate for high deflections which may be encountered in large diameter towers. The trusses are designed to support not only dynamic loadings, but also a concentrated load of 250 pounds or more at any point without exceeding

the tangential stress limits in extreme fibers. "Explosion proof" trays designed to withstand a load of 600 lbs. per sq. ft. or more from either top or bottom side may be made for special applications.

Truss Gap

The distance between the centerline of Ballast units across a truss is $4\frac{1}{4}$ " for lap joints and $3\frac{1}{2}$ " for butt joints. The $4\frac{1}{4}$ " can be reduced when necessary by use of special clamps.

Tray Ring Gap

The center of a Ballast unit can be placed no closer than $1\frac{1}{4}$ " from the tray ring to prevent interference. However, due to tower out-of-roundness, this distance could be as much as $1\frac{1}{4}$ " plus $\frac{1}{4}$ of 1% of the tower diameter after trays are installed.

Tray Diameter

The diameter of the tray deck must be properly sized to allow for tower out-of-roundness, weld metal at the tray ring, etc. It is standard practice to allow $\frac{3}{4}$ " clearance between the edge of the tray deck and the tower shell when using $1\frac{1}{2}$ " and 2" wide rings; 1" is standard for $2\frac{1}{2}$ " wide rings; and, $1\frac{1}{2}$ " is standard for 3" rings and wider.

Circular Downpipes and Ducts

Circular downpipes or rectangular ducts are frequently used at transition trays, chimney trays, accumulator trays, from the bottom tray sump to the bottom of the tower, with cartridge type trays, etc. The collection area or recessed sump to which the downpipe is attached is sized as if it were a conventional downcomer by methods given previously. The sump should be at least 15" deep. A velocity of 2 to 3 ft/sec can be used to size the duct.

Channels for Liquid Flow

A recessed sump beneath the center or off-center downcomer of two and four pass trays is frequently used to conduct liquid to the side of the tower for withdrawal as a sidestream or as circulating reflux. Similarly, channels are sometimes used to distribute non-flashing feed liquid to multipass trays in lieu of feed pipes and distribution headers. If the channel width is smaller than the nozzle, a box is placed at the end of the channel so as to encompass the nozzle. A velocity of not more than 2.5 ft/sec based on the cross sectional area of the channel is recommended.



For more information about the Koch-Glitsch trademarks listed below, visit the Koch-Glitsch Web site at www.koch-glitsch.com.

Trays

BALLAST™ tray
Bi-FRACT™ tray
FLEXILOCK™ tray construction
FLEXITRAY™ valve tray
HORIZON™ technology
KITTEL™ tray
MAX-FRACT™ tray
MINIVALVET™ tray deck
OMNI-FIT™ technology
PLUS™ technology
PROVALVET™ tray
PURGET™ downcomer
SATURN™ technology
SPEED-WAY™ manway
SUPERFLUX™ tray
SUPERFRAC™ tray
TRITON™ tray
ULTRA-FRACT™ tray
VARIOFLEX™ tray

Logos & service marks

KG-TOWER and Design™ (service mark)
"K" KOCH-GLITSCH™ (logo)
KOCH-GLITSCH™ technology
THE SEPARATIONS COMPANY™ (service mark)

Packing

BETA RING™ random packing
CASCADE MINI-RINGS™ random packing
CMR™ random packing
ETAPAK™ random packing
FLEXIGRID™ severe service grid
FLEXIPAC® structured packing
FLEXIPAC® HCT™ structured packing
FLEXIRING™ random packing
GEMPAK™ structured packing
GLITSCH GRID™ severe service grid
GOODLOET™ mesh structured packing
HY-PAK™ random packing
IMTP™ random packing
INTALOX™ structured packing
INTALOX™ Packed Tower Systems technology
INTALOX PACKED TOWER SYSTEMS WITH PROCESS TOWER "L"
INTALOX™ SNOWFLAKET™ random packing
INTALOX™ ULTRA™ random packing
KATAMAX™ structured packing
KFBET™ packing
PROFLUX™ severe service grid
ROSEMAX™ structured packing
Super INTALOX™ Saddles random packing

Separations technology

COALEX™ liquid-liquid coalescing media
DEMISTER™ mist eliminator
DEMISTER-PLUS™ mist eliminator
FLEXICHEVRON™ mist eliminator
FLEXIFIBER™ mist eliminator
FLEXIPEAK™ mist eliminator
KOCH-OTTO YORK™ separations technology
OTTO YORK and Design (Football)™
KY-FLEX™ liquid-liquid coalescing media
KY-MESH™ liquid-liquid coalescing media
TYPE "D" SAFETY SCRUBBER™ mist eliminator housing
YORK-EVENFLOW™ vane inlet device
YORKMESH™ knitted wire mesh

Software

AHOP™ Automated Hardware Ordering Program
BATCHFRAC™ software utility
KG-TOWER™ equipment rating program
RATEFRAC™ software utility

Liquid-liquid extraction equipment

KARR™ column
SCHEIBEL™ column

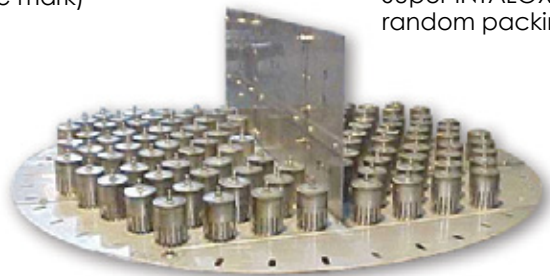

Koch-Glitsch Corporate Offices

Worldwide Headquarters

Koch-Glitsch, LP

4111 East 37th Street North | Wichita, KS 67220 - United States | tel: (316) 828-5110 | fax: (316) 828-7985

Europe

Koch-Glitsch Italia S.r.l.

Via Torri Bianche, 3A | 20871 Vimercate - MB - Italy | tel: +39 039 6386010 | fax: +39 039 6386011

Asia

Koch Chemical Technology Group Singapore Pte. Ltd.

260 Orchard Road, #11-01-09
The Heeren | Singapore 238855 | tel: +65-6831-6500 | fax: +65-6835-2031

Koch-Glitsch (a division of Koch Chemical Technology Group India Pvt. Ltd.)

10th Floor, Corporate Park II
Sion-Trombay Road | Chembur, Mumbai 400 071 - India | tel: +91 22 6771 7171 | fax: +91 22 6771 7161

For a complete list of our offices and facilities, visit us on the Web at www.koch-glitsch.com.

Emergency Numbers

United States/Latin America: 1-888-KOCH-911 (mass transfer), 1-316-207-7935 (mist elimination),
or your local Koch-Glitsch office.

Canada: 1-905-852-3381 (Uxbridge, Ontario).

Europe/Middle East/Africa: +39-06-928-911 (Italy), +44-1782-744561 (UK),
or your local Koch-Glitsch office.

Asia: +65 6831-6500 (Singapore) or your local Koch-Glitsch office.

Trademarks

BALLAST, KOCH-GLITSCH, and "K" KOCH-GLITSCH are trademarks of Koch-Glitsch, LP and are registered in the USA and various other countries. All other trademarks, service marks, or registered trademarks that appear in this document are the trademarks or service marks of their respective owners.

Legal Notice

The data in this bulletin are for general information only and are based on tests carried out under conditions which may not apply to your requirements. No warranties or guarantees are expressed or implied. No information contained in this bulletin constitutes an invitation to infringe any patent, whether now issued or issued hereafter. All descriptions and specifications are subject to change without notice.